

# **Section 25**

## **Rigging Procedures**

---

**Procedures covered in this section:**

Review all prints and follow all details of this section thoroughly. Although many details may repeat previous instructions given throughout this manual, we feel that this is absolutely necessary to stress the importance of the rigging procedures.

**Cards used in this section:**

None

**Prints used in this section:**

Review all prints.

**Templates used in this section:**

None

**Tools required for this section:**

Adjustable wrench 10"	Dial indicator with	Pliers	Screwdrivers	Yardstick
Allen wrenches	magnetic base	Protractor level	Straight edge	
Belt tension tool	Drift punch	Ruler	Tape measure	
Dial calipers	Mallet	Spring Scale	Torque wrench	

Ratchet with sockets of the following sizes: 1/4", 5/16", 3/8", 7/16", 1/2", 9/16", 11/16", 3/4", 7/8"

Wrenches of the following sizes: 1/4", 5/16", 3/8", 7/16", 1/2", 9/16", 11/16", 3/4", 7/8"



### **RIGGING: TAIL BOOM (E09-2000)**

The purpose of the tail boom is to hold the trim fins and the tail rotor in the desired location. If the trim fins and tail rotor are not in the proper location and set at the correct angle, the helicopter will not respond correctly in flight. To have the best stability, the following angles and distances must be correct:

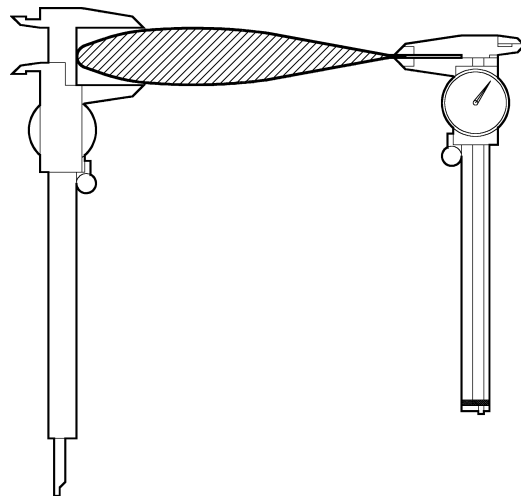
1. The angle of the top of the tail boom should be 2-1/2 degrees more than the angle of the square drive tubes of the airframe.
2. The horizontal trim fin chord line should be parallel with the top of the tail boom.
3. The vertical trim fin chord line should align 15" to 16" to the pilot side from the center of the main rotor shaft.

#### **Photo #1**

To verify that the chord line of the horizontal trim fin is parallel with the top of the tail boom, measure the thickness on both the leading and trailing edge. Divide each measurement by 2 to find the distance from the top of the fin to the chord line at that point.  
Example:

Leading edge:  $.980" \div 2 = .490"$

Trailing edge:  $.088" \div 2 = .044"$

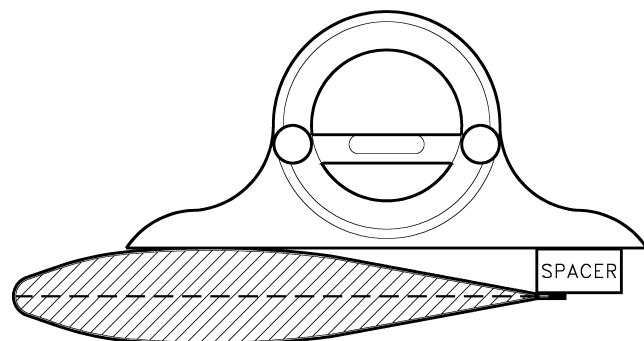


#### **Photo #2**

Subtract the smaller number from the larger.  
Example:

$.490" - .044" = .446"$

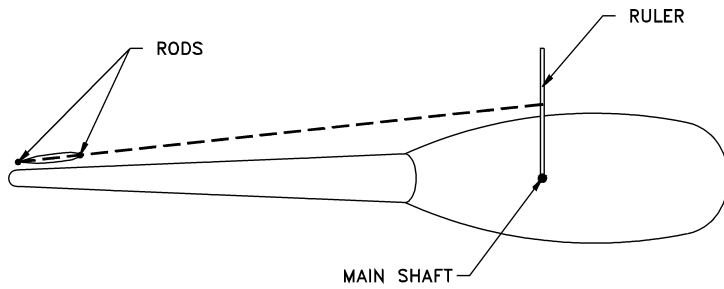
Sand or grind a small piece of wood to that thickness, to be used as a spacer. Place the spacer on the trailing edge. Rest the protractor level on the leading edge and on the spacer. The protractor is now parallel with the chord line of the fin. Check that the chord line is parallel with the top of the tail boom.





**Photo #3**

To verify that the vertical trim fin is at the correct angle, tape a piece of welding rod on the front and rear of the fin, extending about 1".



**Photo #4**

Sight across the welding rods from behind the ship. The rods should align 15-1/2" to the pilot's side of the main rotor shaft. Drawing shows top view of this procedure.

### **RIGGING: CYCLIC CONTROL (E14-2000)**

The purpose of the cyclic control is to maintain the balance of the helicopter when it is in the air by tipping the swash plate to the correct angle in reference to the main rotor shaft. If the angles are not within the specified range of travel, the sensitivity of the control will be affected, possibly to the extent of being unable to control the helicopter. The angles that will give the pilot the best control throughout all maneuvers are as follows:

1. Total travel from the left to the right stops should be 52 degrees, with equal number of degrees both directions from the center.
2. Total travel from the rear to the front stop should be 52 degrees, with the rear stop set for pilot comfort.

#### **Photo #5**

Set the protractor to read 26 degrees and place it on the side of the cyclic handle. Move the cyclic to the left until the bubble centers.

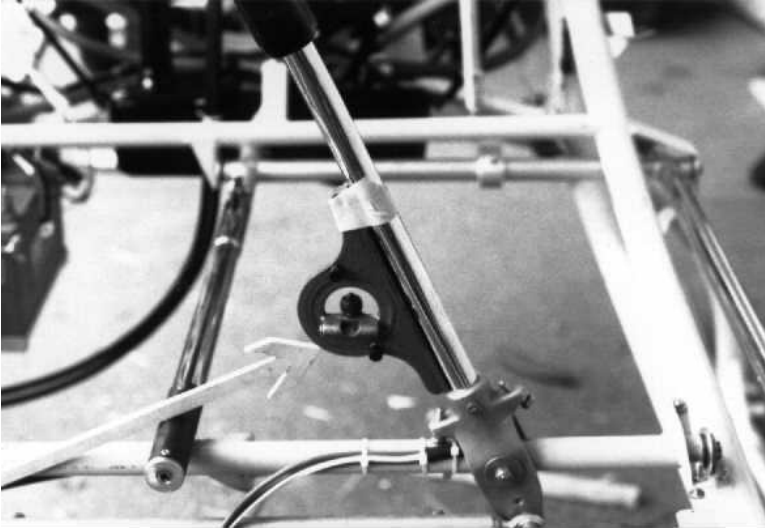


#### **Photo #6**

Adjust the stop bolt so it makes contact with the cross shaft.

Note: If 26 degrees cannot be achieved, remove the jam nut from the bolt for more travel. Use one or more flat washers under the head of the bolt and tighten the bolt against the washer(s). Use Loctite to prevent the bolt from loosening.





**Photo #7**

Set the protractor level to read 26 degrees in the other direction, leaving it in place on the side of the cyclic. Move the cyclic to the right until the bubble centers.



**Photo #8**

Adjust the stop bolt so it makes contact with the cross shaft.



**Photo #9**

Set the protractor level to read 26 degrees and place it on the rear of the cyclic stick. Move the cyclic to the rear until the bubble centers.

**Photo #10**

Adjust the rear stop bolt against the stop bracket.



**Photo #11**

Set the protractor to read 26 degrees in the other direction and move the cyclic forward until the bubble centers.



**Photo #12**

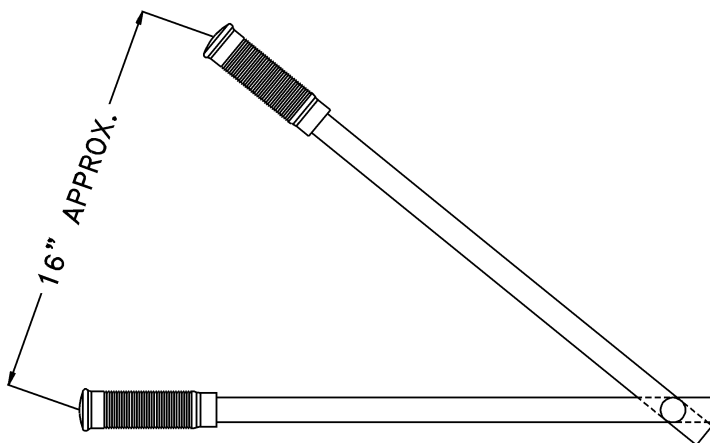
Adjust the forward stop bolt against the forward stop bracket.



### **RIGGING: COLLECTIVE CONTROL (E15-2000)**

The purpose of the collective is to control the amount of pitch on the main rotor blades and the amount of throttle on the engine, which determines how much lift you have to work with. To obtain the best control of both items (pitch of blades and throttle), the collective control must be set up as follows:

1. The collective control must have freedom of movement throughout its full range of travel, from the bottom of the pocket in the floor pan to where it contacts the airframe bracket. The handle should travel approximately 16 inches.
2. The throttle is checked by placing the collective in the full down position and twisting the throttle from stop to stop. Throttle roll should be approximately 143°. The throttle transfer rod should rest on the stops at each end of travel. With throttle in the fully closed position, the "B" control arm (pilot's side) should be 17 to 18 degrees in reference to the collective cross shaft. There should be no binding of the throttle linkage through the full range of movement of the collective handle.
3. With the collective in the full down position and throttle fully closed, the throttle position reading on the digital display should read 0%. Raise the collective without twisting the throttle. The throttle position should remain 0% throughout the full range of travel. With the collective in the full down position and the throttle fully open, the digital display should read 70%. Raise the collective to mid-point without twisting the throttle. The display should read 100%.
4. 100% throttle should be available at hover pitch of main rotor blades (5 to 6 degrees or approximately 1/2 to 2/3 collective stick travel).
5. There should be NO throttle opening with collective handle full up and throttle full off.
6. Main rotor blade pitch throughout full travel should not exceed 11 to 11-1/2 degrees total movement. Example: If negative pitch is 2 degrees then positive pitch should be 9 to 9-1/2 degrees.



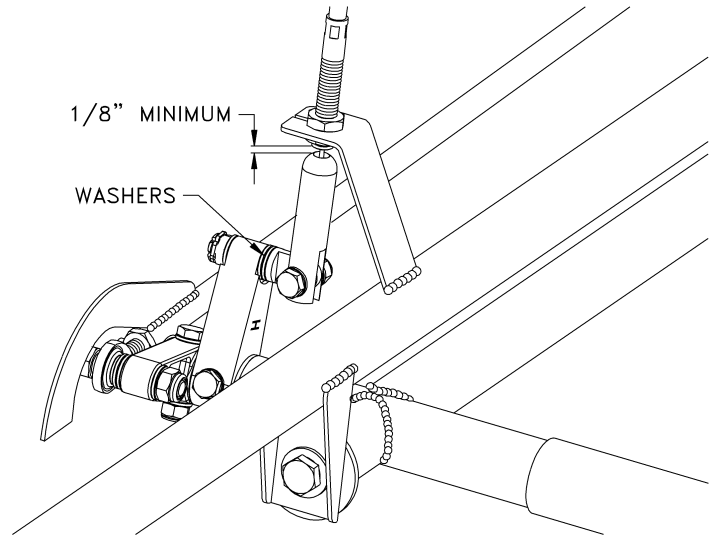
**Photo #13**

The collective should travel approximately 16 inches from full down to full up position. It must have freedom of movement throughout its full range of travel, from the bottom of the pocket in the floor pan to where it contacts the airframe bracket.

**Photo #14**

Both the eye bolt on the control arm and the aluminum clevis on the throttle cable must be able to pivot freely without binding.

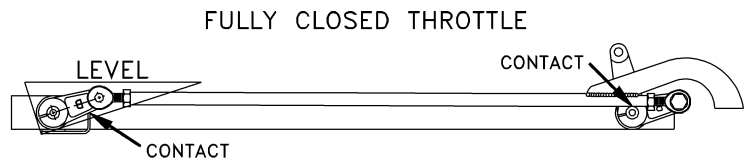
With the collective in the full down position and the throttle rolled off, the 3/16 hole in the eye bolt should be 1" to 1-1/16" from the rear of the collective cross shaft, as shown on print E15-2000. Start with 1/8" minimum between the end of the cable housing and the aluminum clevis. These are the initial settings. Changes can be made as necessary by adjusting the nuts on the cable housing and/or adding or removing washers on the eye bolt to get the correct throttle correlation.



**Photo #15**

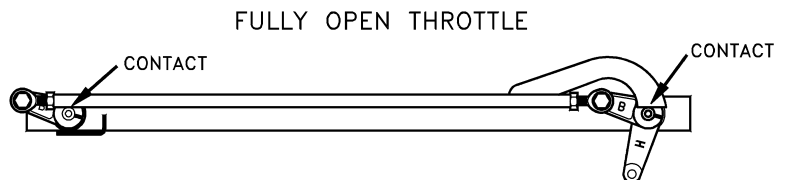
With the collective in the full down position, twist the throttle from stop to stop. Throttle roll should be approximately 143°.

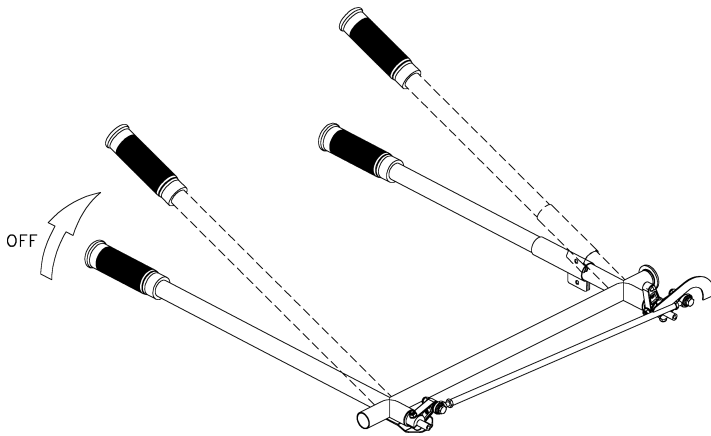
With throttle in the fully closed position, both stops should make contact at the same time. The "B" control arm (pilot's side) should be 17 to 18 degrees in reference to the collective cross shaft. Use the triangular template to verify the angle. (See Section 10.)



**Photo #16**

With the collective in the full down position and throttle fully open, both stops should make contact at the same time. There should be no binding of the throttle linkage through the full range of movement of the collective handle.

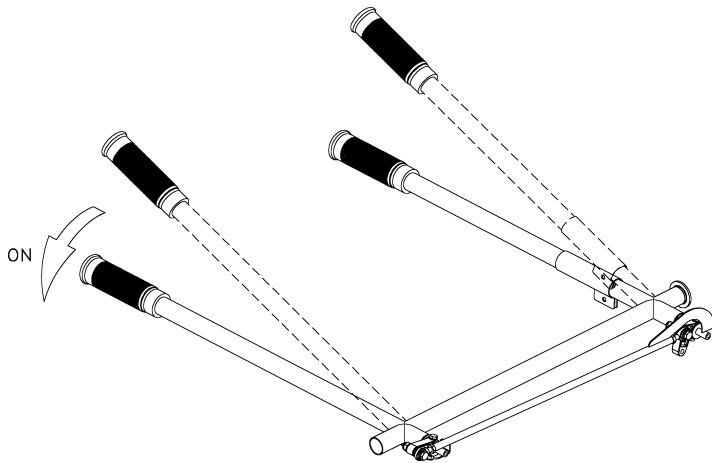




**Photo #17**

The FADEC digital display can be used to check correlation of the collective and throttle. With the collective in the full down position and throttle fully closed, the throttle position reading on the digital display should read 0%. Raise the collective without twisting the throttle. The throttle position should remain 0% throughout the full range of travel.

Note: If 0% throttle opening cannot be maintained throughout full range of collective travel, there may be too much travel and an upper limit stop may need to be added. This stop can be attached to the collective bracket on the pilot's side of the airframe.



**Photo #18**

With the collective full down and throttle rolled ON, throttle position on the digital display should be about 70%. Raise the collective to mid point without twisting the throttle. Throttle position should increase to 100%.

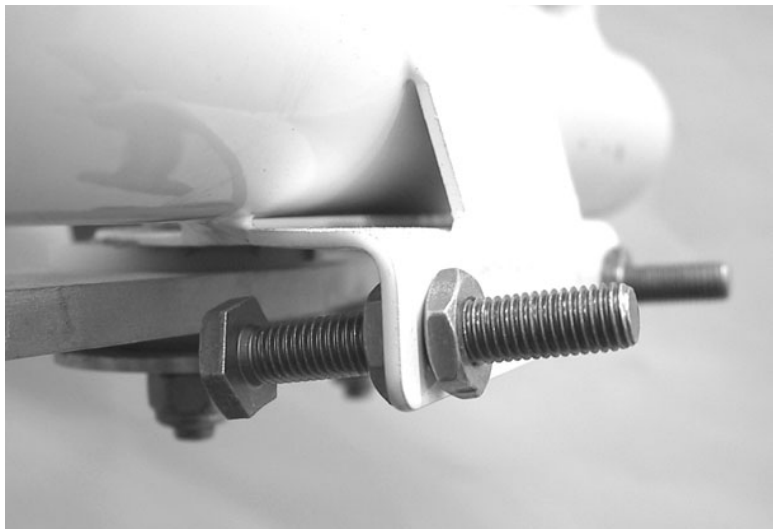
**RIGGING: DIRECTIONAL CONTROL (E16-2000)**

The purpose of the anti-torque pedals is to control the pitch of the tail rotor blades. Changing the pitch on the tail rotor controls which way the helicopter will turn. To have enough control in all maneuvers and power settings, set the pedal travel as follows:

1. The anti-torque pedal control should have freedom of travel from stop to stop with the push/pull cable traveling 2-7/8".

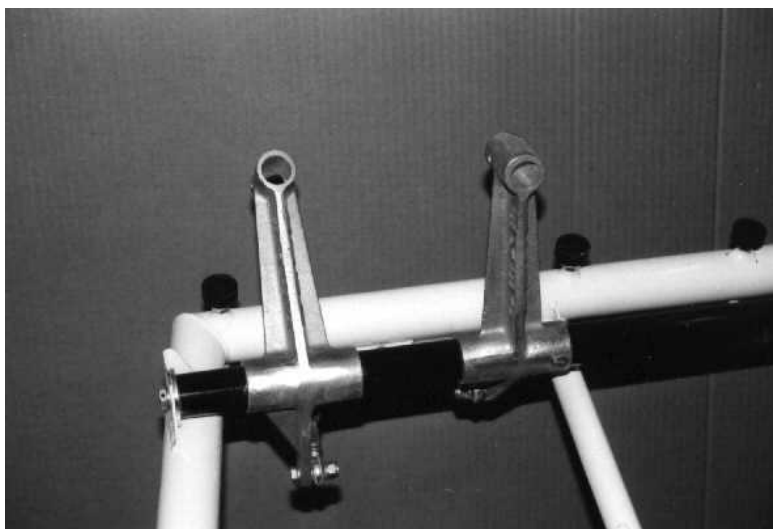
**Photo #19**

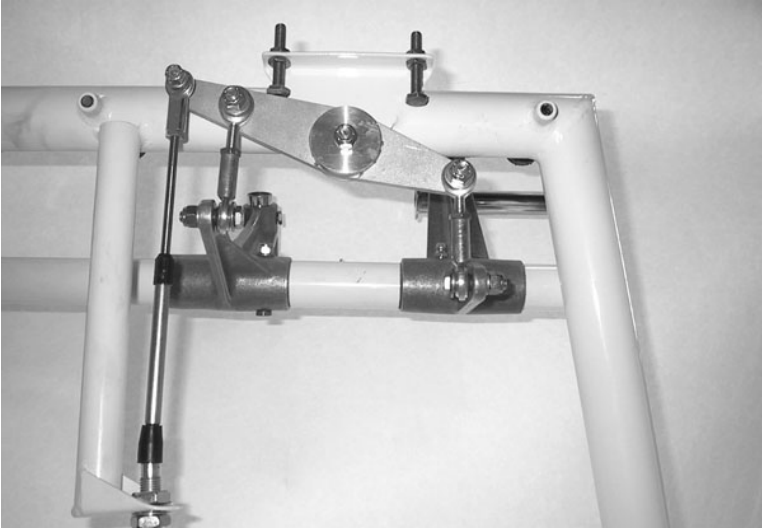
These are the stop bolts used to set the travel of the pedals.



**Photo #20**

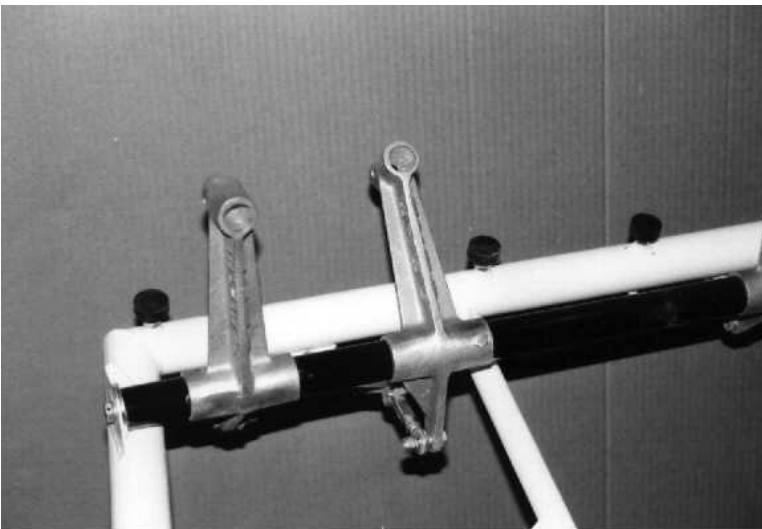
Push the left pedal to the stop.





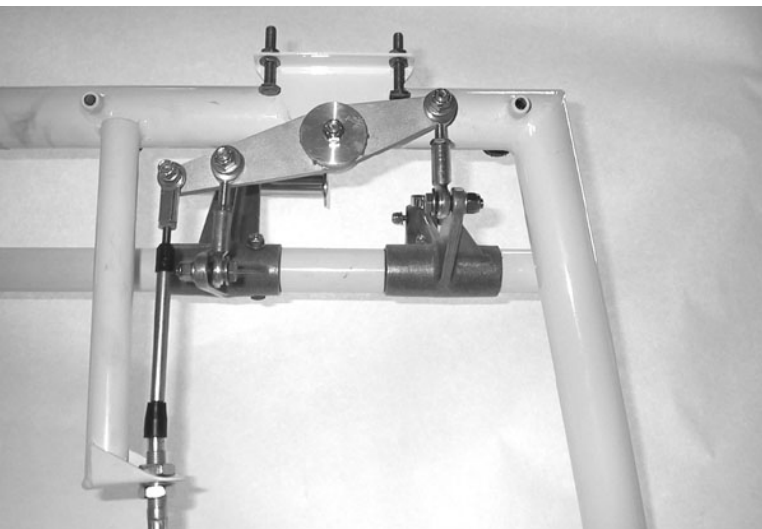
**Photo #21**

The tail rotor directional control cable should move forward.



**Photo #22**

Push the right pedal to the stop.



**Photo #23**

The tail rotor directional control cable should move to the rear. The total travel of the cable should be 2-7/8".

**RIGGING: TAIL ROTOR (E17-2000)**

The purpose of the tail rotor is to counter the effect of torque. If the tail rotor does not work properly, the helicopter will turn as soon as it becomes light on the skids and there will be no way to stop it. Follow these steps when rigging the tail rotor:

1. The rod end on the pitch horns should be centered over the 3/8" bolt holding the barrel to the shaft.
2. When the right pedal is against the stop, set the pitch on the tail rotor at 24 degrees positive pitch with the barrel 90 degrees to the shaft.
3. When the left pedal is against the stop, set the pitch on the tail rotor at 8 degrees negative pitch with the barrel 90 degrees to the shaft.

**Photo #24**

The rod end on the pitch horn must be centered over the 3/8" bolt that holds the barrel to the shaft. Use washers if necessary to achieve this alignment. If more than 4 washers are required to position these rod ends, contact RotorWay.



**Photo #25**

When the left pedal is against the stop, the tail rotor should have an 8 degree negative pitch. Use the tail rotor template and protractor level when setting the pitch.





**Photo #26**

When the right pedal is against the stop, the tail rotor should have a 24 degree positive pitch. Use the tail rotor template and protractor level when setting the pitch.

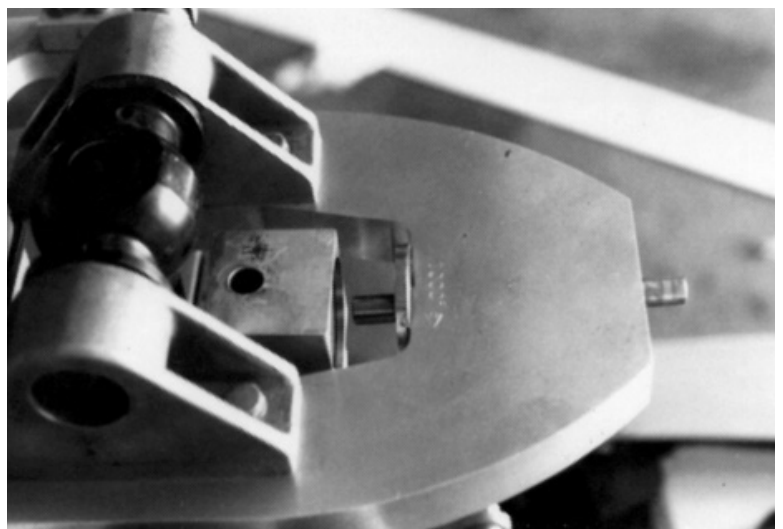
### **RIGGING: MAIN ROTOR BLADES (E20-2000)**

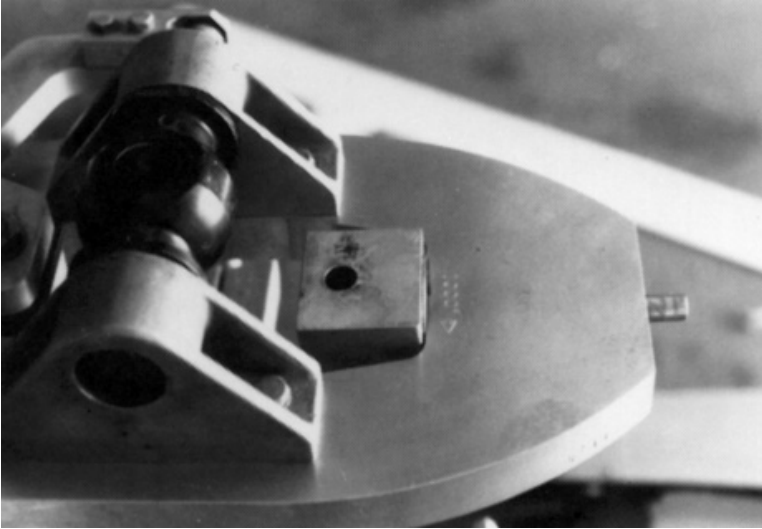
The main rotor blades are the wings which lift the helicopter and pull it in the direction that you are flying. When the two blades are made the same and are adjusted so they lift the same amount, the helicopter is a smooth flying machine. Rig the rotor system as follows:

1. The rotor hub plate must be shimmed correctly on the main rotor shaft. Center of the outboard pitch pins and the center of the main rotor shaft must be in a straight line to within .0005". (Total Indicated Reading of .001".)
2. The main rotor shaft should be 90 degrees to the ground in all directions.
3. Center of the 9/16" retention bolt should be within 1.985" to 1.990" from the leading edge of the rotor blades.
4. Thrust blocks should be installed correctly on the rotor hub.
5. Both rotor blade chord lines should be level, with the control rod disconnected.
6. Both rotor blades should be the same weight.
7. Both pitch horns should be mounted to the retention strap the same.
8. Set the pitch on the rotor blades using the control rods, with the swash plate 90 degrees to the main rotor shaft. With the collective full down, both blades are set at 1-1/2 degrees negative pitch.
9. Check the pitch on the main rotor blades when the collective is in the full up position. The positive pitch should be 9-1/2 degrees positive.
10. The teeter travel must be between 14 and 15 degrees total movement.

#### **Photo #27**

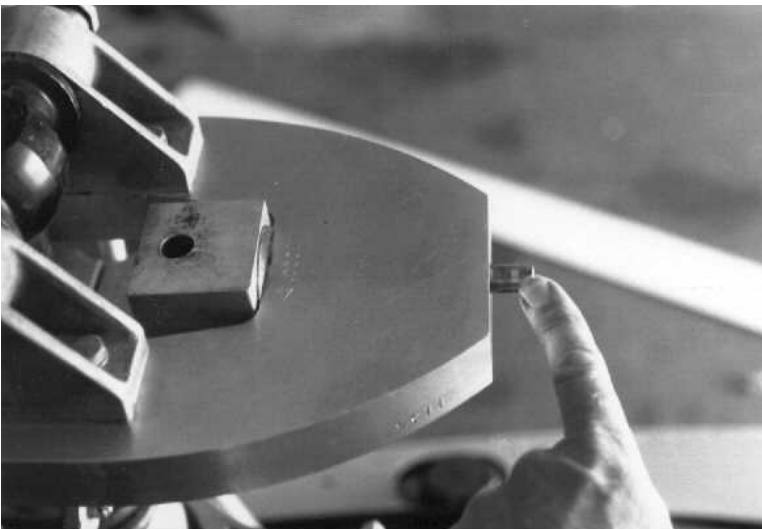
To mount and adjust the main rotor blades, do the following: clean the pitch pins (inboard and outboard) and apply a thin coat of grease. Install the thrust blocks with the master block on the end of the hub with the serial number.





**Photo #28**

Check fit to inside of hub.



**Photo #29**

Line up the aligner block bearing (on the blade) with the outboard pitch pin, and slide the blade in place to install the 9/16" retention bolts. The blades must be held in the pre-coned position and not allowed to droop until both 9/16" bolts are tightened. Force the blades outward before tightening the 9/16" bolts to ensure that the thrust block is seated properly.

Note: After the first blade is in place, rest it on a ladder while the second blade is being installed.



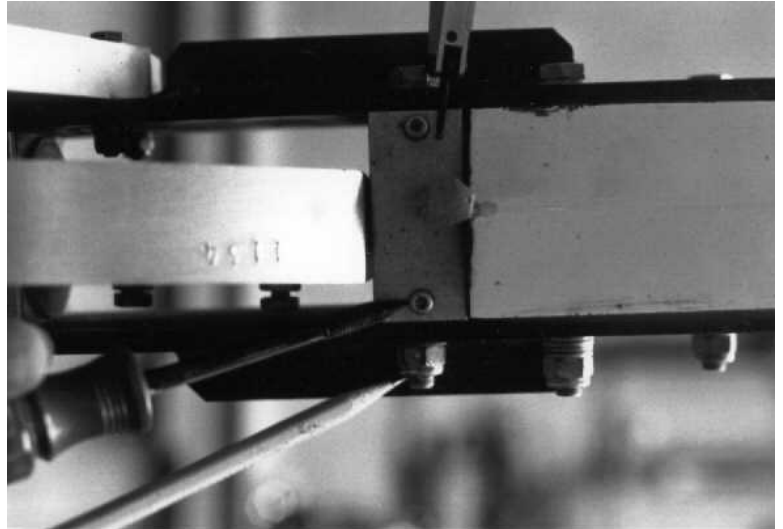
**Photo #30**

The rotor hub should be level laterally. If necessary, shim under the skids to level the hub. When the rotor blades are hanging unsupported on the hub, they must feather freely or it will be impossible to do a static lead/lag adjustment. If the blades do not feather freely, observe the gap between the aligner block bearing and the end of the hub plate. This gap should be approximately .040". The gap can be reduced by tapping the blade inward. Position the blade in the coning angle before tapping inward.

**Photo #31**

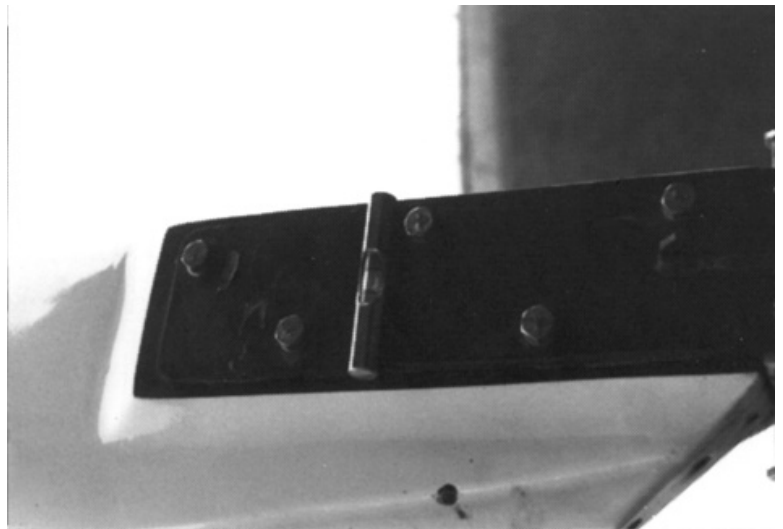
Loosen the 5/16" aligner block bolts and the allen screws. Use the all thread 1/4" bolt to level both blades. The blade sweeps on the 9/16" retention bolt and pivots on the inboard and outboard pitch pins. When the blade is aligned with the pitch pins, it will level itself if it is free to pivot on the pitch pins.

Note: If during lead/lag adjustment the blade does not feather freely, it may be necessary to re-seat the thrust block as in photo #32 and tap the blade inward as in photo #33. Be sure to have the blades in the coning angle while doing this.



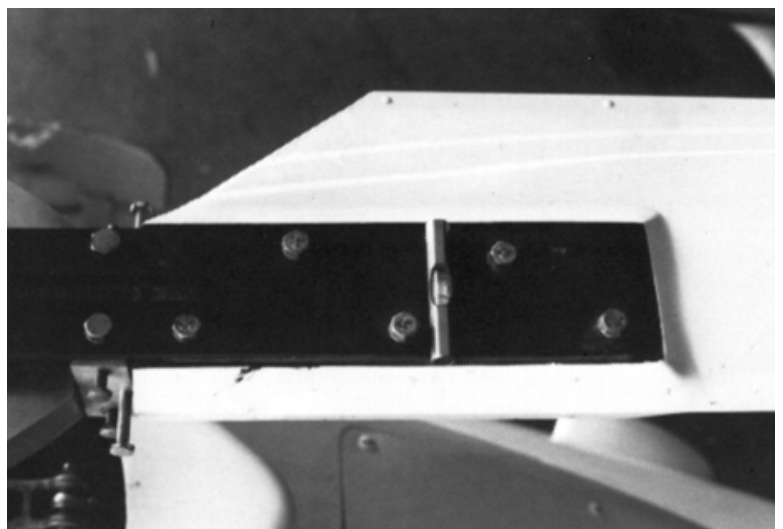
**Photo #32**

The slave blade is level when the blade is aligned with the pitch pins.



**Photo #33**

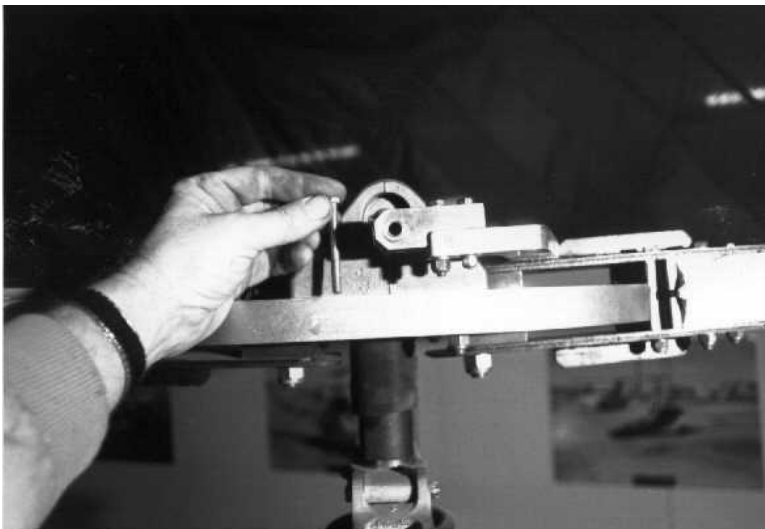
The master blade is level when the blade is aligned with the pitch pins.





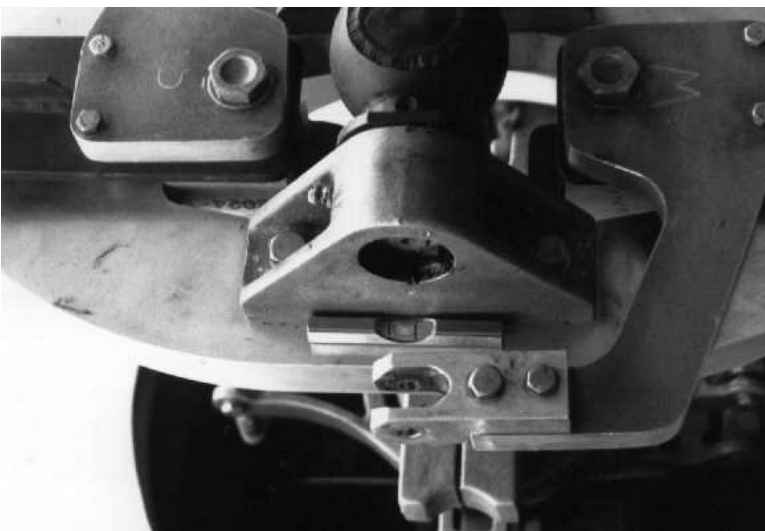
**Photo #34**

The hub plate, master blade and slave blade should be level when all the bolts are tight and the static lead/lag balance is done correctly.



**Photo #35**

To check to see if both main rotor blades are the same weight, replace the 3/8" bolts in the teeter block with 1/4" bolts one at a time and remove the snap ring on the main drive pin to allow the hub to teeter freely.



**Photo #36**

Place the level on the hub plate under the main drive pin so the weight of the level will not affect the balance of the blades.

**Photo #37**

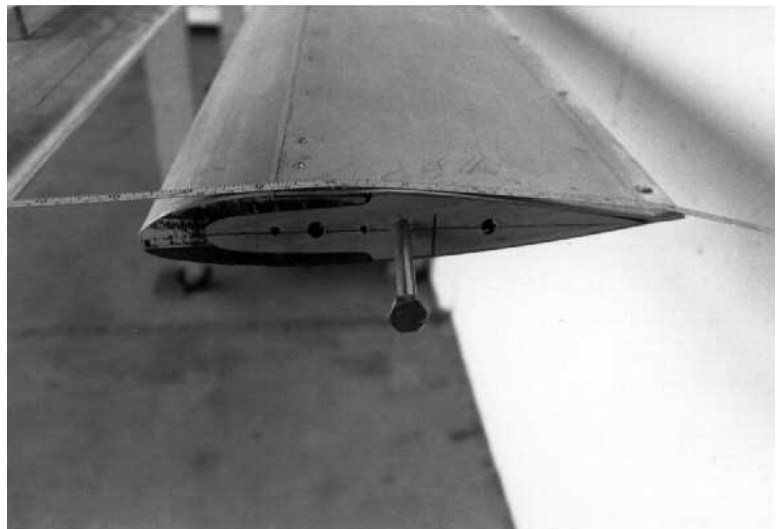
Remove weight from the tip weight in the heavier blade until the bubble on the level centers. Be sure the wood end caps and their screws are on the ends of the blades when balancing. Teeter the blades a few times and see if they balance each time. This will ensure a good balance.



**Photo #38**

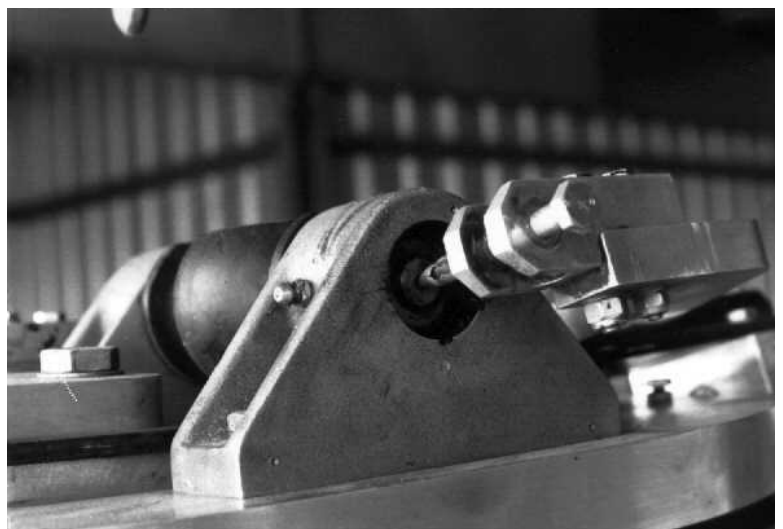
When the balance is correct, install the tip plugs in the end of the blades, securing them with 3M 2 part epoxy adhesive, also called "blade glue" and wood screws. Remove the 1/4" bolts and re-install the 3/8" bolts in the teeter blocks one at a time. Re-install the snap rings on the main drive pin.

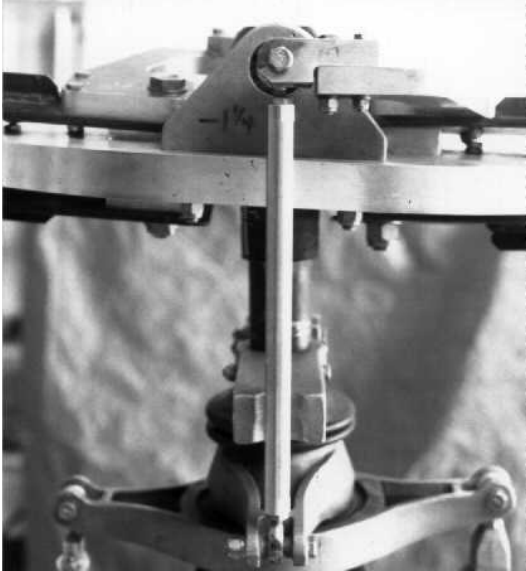
Note: Use a long 1/4" bolt in the vent hole of the tip plug for easier installation.



**Photo #39**

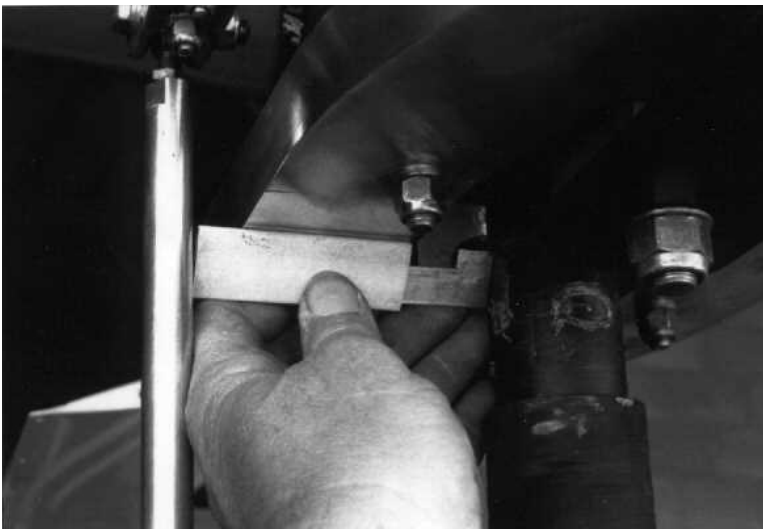
To locate the position for the pitch horns do the following: Grind the end of a long 5/16" bolt to a point and install it in the pitch horn clevis. Raise the pitch horn until you can align the point of the bolt with the center of the drive pin. Rotate the pitch horn if necessary to achieve this alignment.





**Photo #40**

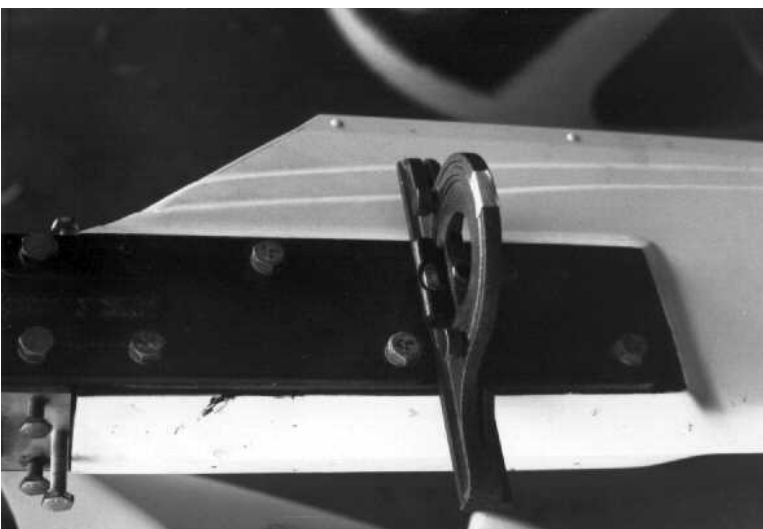
Install the control rods and adjust them so that the swash plate, rotor hub and both rotor blades are level.



**Photo #41**

Slide the rubber collar down as far as possible and check the distance between the main rotor shaft and the control rods. Both sides must be equal. When all items in photos #42 and #43 are correct, the pitch horn is in the correct position. Use the holes in the pitch horns to locate and drill the two 3/16" holes in the straps.

Note: If the pitch horns are set correctly, the pitch of both blades will be the same from full down to full up collective.



**Photo #42**

When setting the pitch on the rotor blade, the rotor hub and swash plate must be level.

Collective down both blades: 1-1/2 degrees negative pitch.

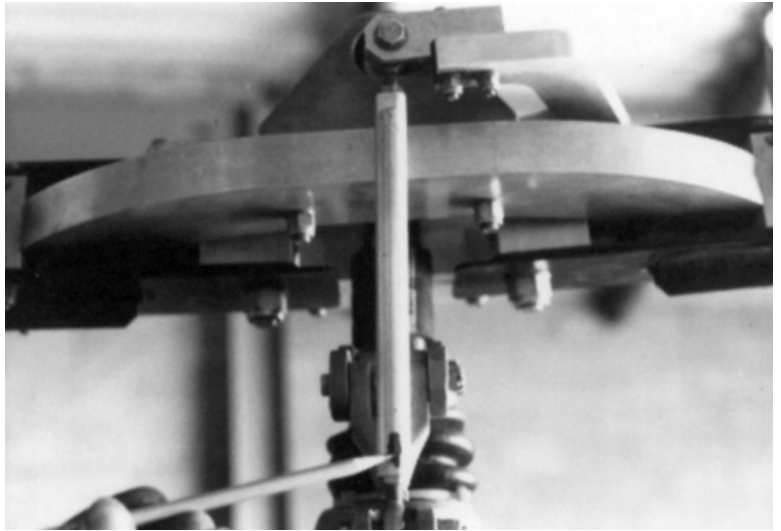
Collective up both blades: 9-1/2 degrees positive pitch.

The collective and cyclic controls should not interfere with each other throughout travel.

**Photo #43**

It may be necessary to change the track setting to make the blade track while turning, due to the aerodynamics of the airfoils. Make a tracking stick by taping a piece of rubber hose to a small diameter wooden dowel. Grease the hose and raise it until it makes contact with the turning blades (2 strikes minimum), 18" from the tip. Mark the control rods and turn 1/4 turn per adjustment, until both blades hit the tracking stick rubber.

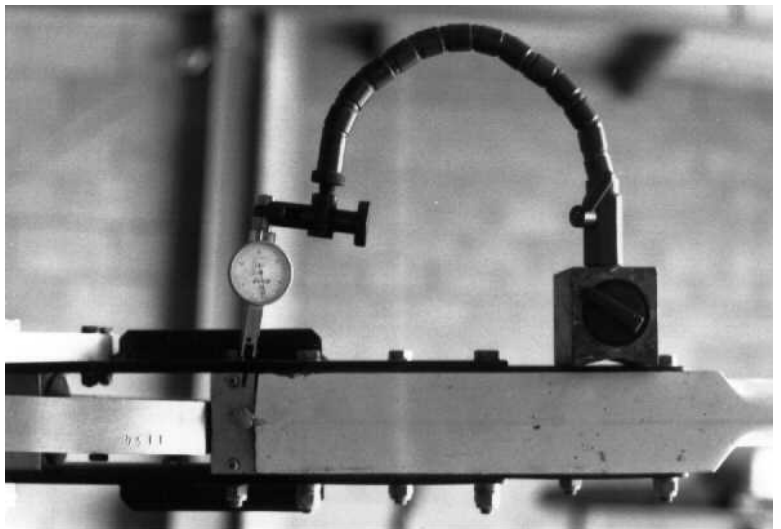
Note: Avoid more than 4 adjustments of 1/4 turn to one blade. It may be necessary to adjust the opposite control rod to maintain proper positive and negative pitch range.



**Photo #44**

Before attempting the dynamic lead/lag adjustments, make sure that the static adjustment is correct. In most cases a level chord line will give best results. It may be necessary to change the static lead/lag adjustment to make the rotor balance while turning.

When changing the lead/lag on the dynamic test, set up the dial indicator as shown, with magnetic base on the longest steel strap and the indicator point on the aligner block. Move .002" per adjustment. Loosen the 5/16" lock bolts and set screws and turn the 1/4" all thread.



**Photo #45**

Use the reflex template and duck bill pliers to change the trailing edge angle for track adjustment to maintain track and smoothness in forward flight. Note: A more precise method of adjusting the trailing edge is to use a dial indicator mounted on the reflex edge fixture, available from the parts department. Detailed instructions are provided with the fixture.



## **RIGGING: MAIN DRIVE BELTS**

The main drive belts turn all the rotating parts in the helicopter. If the belts are dirty or loose, they will slip and the parts will not turn at the correct speed. When this happens, the helicopter will not fly. To get the desired results from the main drive belts, do the following:

1. The belts and pulleys should be clean. Use acetone and a clean cloth to wipe them clean (the cloth should be damp but not dripping with acetone).
2. Be sure the pulleys are properly aligned.
3. Hydraulic clutch and pressure regulator assembly (control valve):
  - A. Note: On initial startup the clutch will go to the engaged position for a short time even though the control knob is in the disengaged position. This is due to the fact that the cylinder works on differential pressure when in the disengaged position. After about 30 seconds the pressure will equalize on both sides of the piston and the cylinder will return to the fully extended or disengaged position. It will operate normally from then on.
  - B. Check for oil leaks at the connections.
  - C. Check that the belts run centered on the idler pulley (not tight against the top or bottom flange).
  - D. Start with the control knob in the full out position. After engine is running smoothly 1 minute or longer, push the control knob into the first stop (this will bring rotor speed up to engine idle speed). Note: Rotor should attain idle engine speed in 20 to 30 seconds after start up. Then push knob fully in and turn to lock. The clutch is now in the fully engaged position.
  - E. There are only two adjustments that can be made to the control valve.
    1. The top adjustment screw (the one immediately under the control knob) controls the initial belt pressure and rate of engagement. By turning this screw counter-clockwise, higher initial belt pressure and a faster rate of engagement can be obtained. Leave it where set (half in) unless more belt pressure is necessary.
    2. The lower adjustment screw controls the pressure in the cylinder which is also belt pressure and is shown on the oil pressure gauge. The oil gauge will show engine oil pressure when clutch is disengaged (knob fully out) and will show cylinder/belt pressure with clutch engaged (knob fully in). Adjust to 45 PSI with clutch fully engaged.

To ensure there is no belt slippage, run to 100 percent rotor RPM at 3 to 4 degrees collective pitch. At gross weight in a hover, engine RPM should not increase significantly (the needles on the dual tach should not split.)

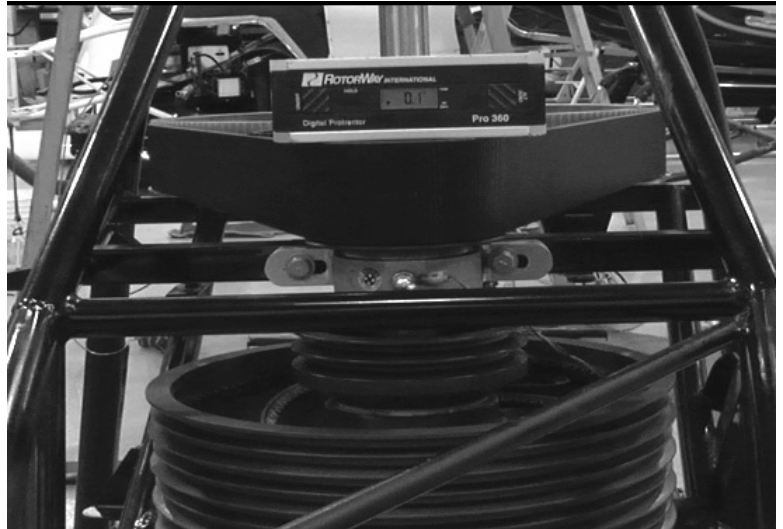
4. When to adjust belt tension: The red silicone O-ring should be a pre- and post-flight inspection item. The cylinder will reach its travel limit when the red silicone O-ring is 1/2 inch from the end of the shaft (before the jam nut). At this point the cylinder cannot keep the belts under proper tension.

When the red O-ring reaches 1 inch to 1-1/8 inches from the end of the shaft, it is imperative to either move the engine forward to tighten the belts, or tighten them by screwing in the rod end on the left (pilot's side) of the piston rod. (The cylinder will still be 1/2 to 5/8 inch from the end of its travel as a safety margin.)

5. From idle to full engine load, the hydraulic clutch cylinder will compensate for 5/8 to 7/8 inch of belt stretch.

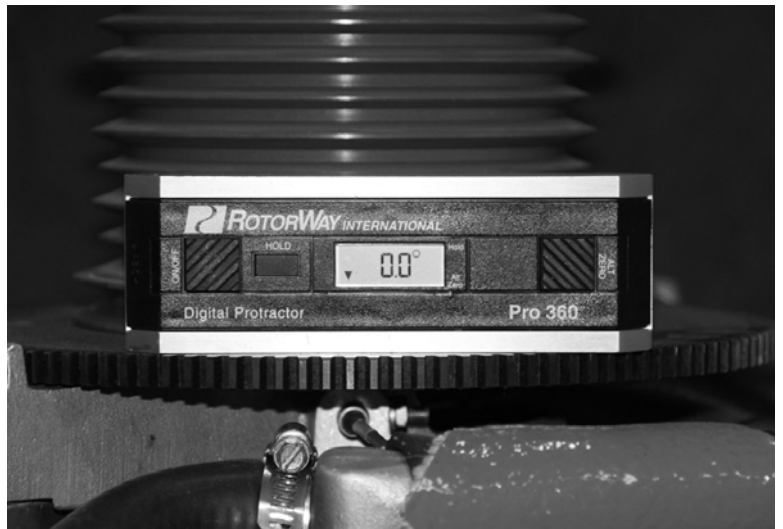
**Photo #46**

Level the secondary pulley by shimming under the skids.



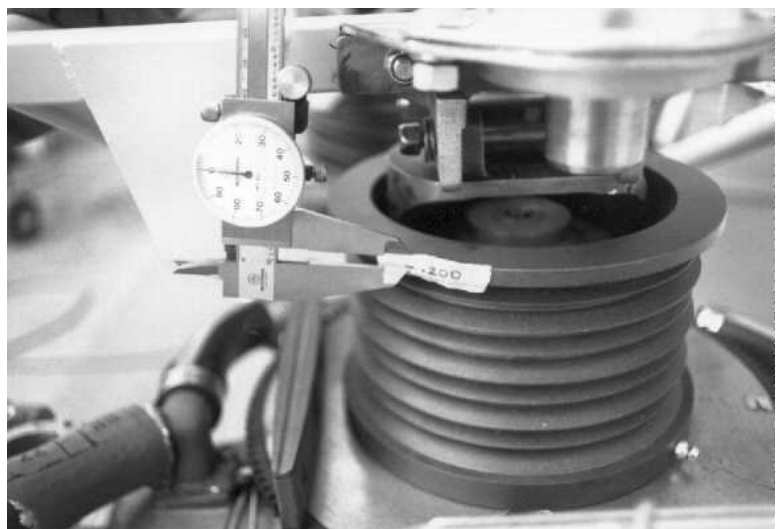
**Photo #47**

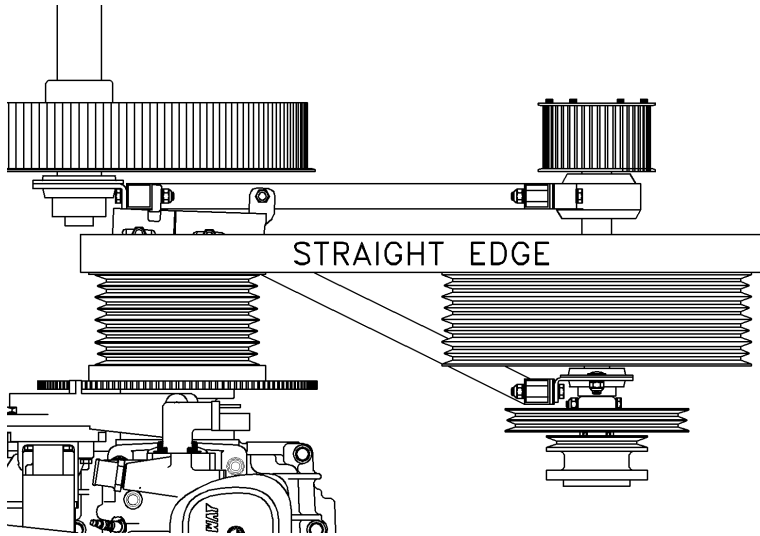
Level the engine flywheel by moving the top and/or bottom of the engine.



**Photo #48**

Mark the side of the engine pulley .200" from the top on both sides of the aircraft. This is necessary because the top of the pulley has approximately .200" more material above the belt grooves than the secondary pulley.





**Photo #49**

Place a straight edge on top of the secondary pulley. The straight edge should be even with the mark on the engine pulley. The up/down position of the idler pulley should be centered on the secondary pulley.



**Photo #50**

Main drive belt tension should be 5/8 to 3/4 inch deflection with 7 pounds pressure. This is measured between the main drive pulley and the secondary pulley on the pilot's side. This is the initial tension with the backside idler pulley not touching the belts.

### **RIGGING: SWASH PLATE**

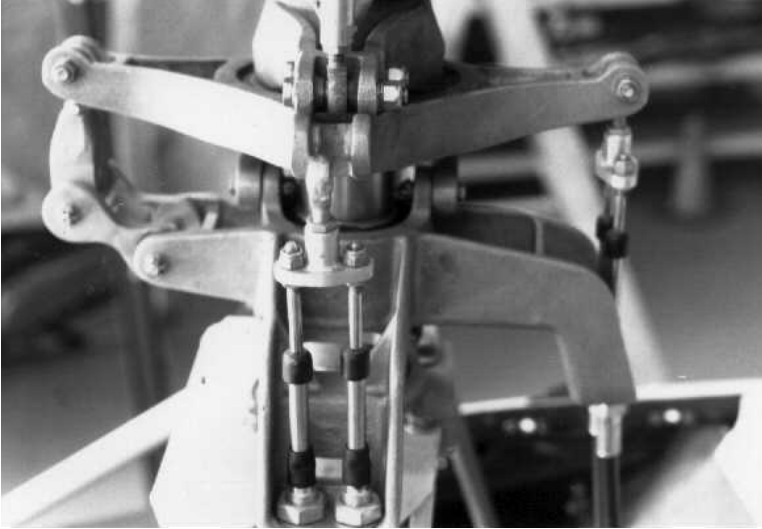
The swash plate is a disc that when tipped at an angle to the main rotor shaft (by cyclic control), makes the main rotor blades tip to the same angle. The swash plate tips the main rotor blades in different attitudes to maintain balance of the helicopter in flight. When rigging the swash plate, do the following:

1. All angles of the swash plate are set in reference to the main rotor shaft.  
NOTE: Use shims under the skids until the main rotor shaft is 90 degrees to the ground both fore/aft and laterally.
2. When the cyclic handle is against the forward stop, the swash plate must tip 5 degrees down in the front, in reference to the main rotor shaft.
3. When the cyclic handle is against the rear stop, the swash plate must tip 5 degrees down in the rear, in reference to the main rotor shaft.
4. When the cyclic handle is against the left stop, the swash plate must tip 5 degrees down on the left, in reference to the main rotor shaft.
5. When the cyclic handle is against the right stop, the swash plate must be 5 degrees down on the right, in reference to the main rotor shaft.
6. Adjust the bias of the cyclic controls as described in this section.

#### **Photo #51**

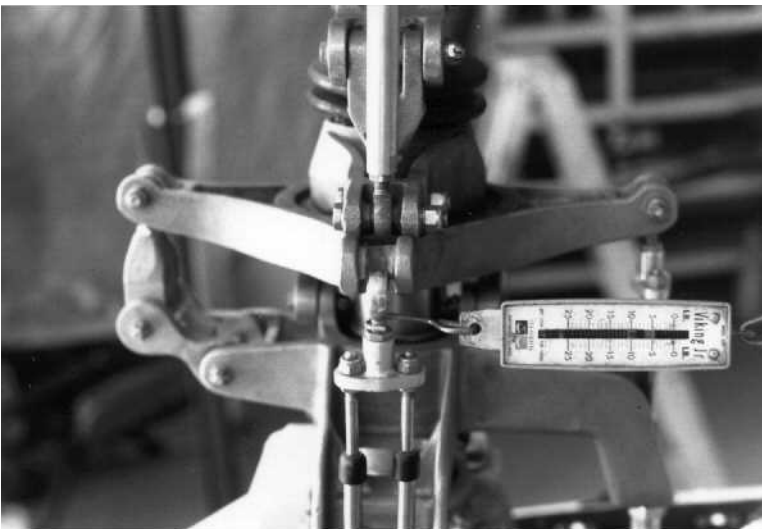
The cyclic control cables shown installed in the cable mount casting.





**Photo #52**

The cyclic control cables have been adjusted to the control "T". Notice the rod end is to one side of the opening.



**Photo #53**

Using a spring scale, pull 4 lbs. to align the rod end with the slot of the swash plate to give the correct bias in the control cables.



**Photo #54**

When the correct bias is achieved on the cyclic control cable, install the rod end in the swash plate opening.

Note: Set the bias of both fore/aft and lateral cables using this method.

**Photo #55**

When setting the swash plate angles, the main rotor shaft must be 90 degrees to the ground. Put two 5/16" bolts in the holes and place a straight edge on them. Set the protractor level 5 degrees and set it on the straight edge. Center the cyclic fore/aft and against the left stop.



**Photo #56**

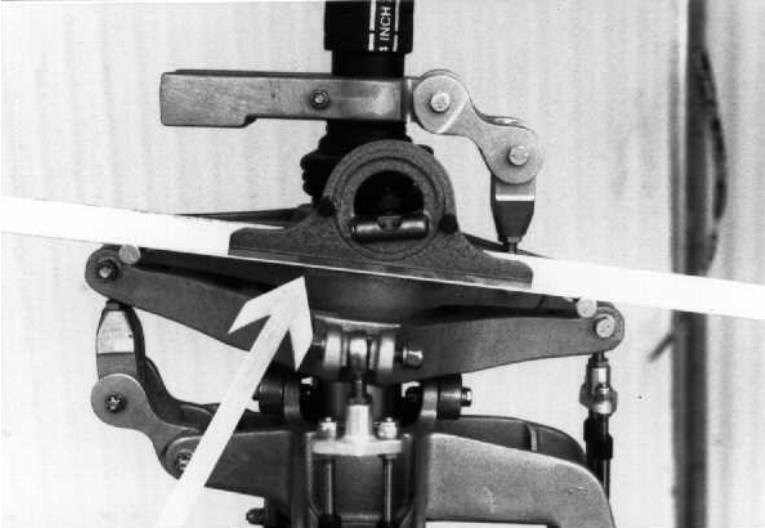
Adjust the rod end indicated by the arrow until the bubble centers.



**Photo #57**

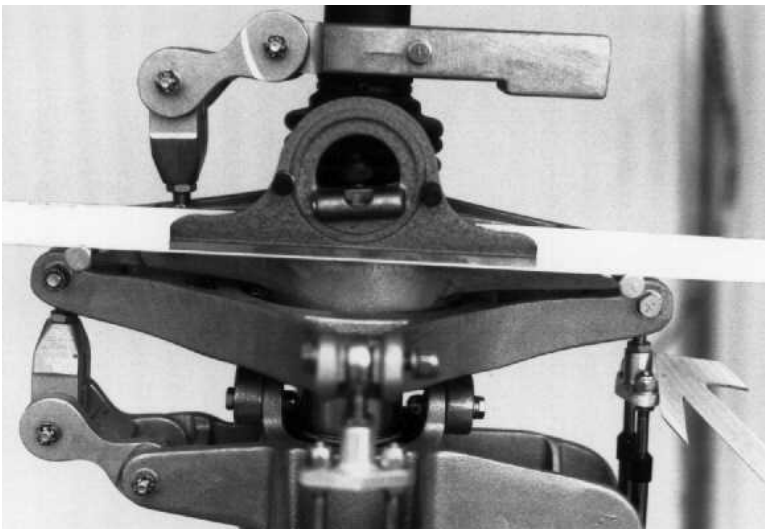
Set the protractor to 5 degrees in the other direction and place it on the straight edge. The cyclic control should be centered fore/aft and against the right side. The bubble should center; if it does not, the ratio of the cyclic and swash plate is off. Check the moment arm of the casting at each end of the cables. (The moment arm is the distance between the pivot point and the attachment point.)





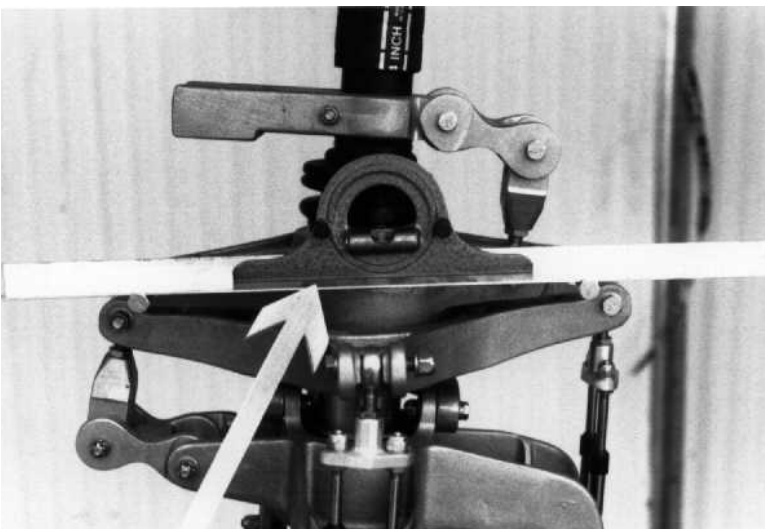
**Photo #58**

Remove the long bolts and rotate the swash plate to check the fore/aft angles. Install the long bolts and straight edge. Set the protractor to 5 degrees and place it on the straight edge. The cyclic should be centered laterally and against the forward stop to set the angle.



**Photo #59**

Adjust the rod until the bubble is centered.



**Photo #60**

Set the protractor to 5 degrees in the other direction and place it on the straight edge. The cyclic should be centered laterally and against the rear stop. The bubble should center. If it does not, the ratio of the cyclic and swash plate is off. Check the moment arm at each end of the control cables.