

Section 11

Drive Train Installation

Procedures covered in this section:

Install main drive belts; install main rotor shaft; mount main drive sprocket to hub; install secondary assembly; install fan and fan pulley; install secondary sprocket and locking assembly.

Cards used in this section:

HARDWARE CARD	E25 CARD 4	E49 CARD 2
E23 CARD 1	E49 CARD 1	

Prints used in this section:

E23-2000	E49-2001
E49-2000	E49-2002

Templates used in this section:

E25-2

Tools required for this section:

Air or electric drill	Drill press	Level	Snap ring pliers	Utility knife
Allen wrench	Files	Pliers	Spring scale	Vise
Band saw	Framing Square	Ruler	Straight edge	
Digital Protractor	Grease pencil or marker	Screwdriver	Tape measure	
Drift punch	Hammer	Side cutters	Torque wrench	

Drill bits of the following sizes: 1/16", 15/64", 1/4", 5/16", Letter "A", Letter "D"

Ratchet with sockets of the following sizes: 7/16", 1/2", 9/16"

Wrenches of the following sizes: 7/16", 1/2", 9/16"

Notes:

- BUILDING SEQUENCE:** Before beginning any work on the drive train, read Sections 11 through 16 to become familiar with the entire procedure. Follow this sequence when assembling the drive train components:
 - Install the main rotor shaft. Do not Loctite bearings or set lock rings yet because the main shaft will be removed to fit other components.
 - Align the secondary drive unit with main rotor shaft, shim as necessary, and final install.
 - Install engine and shim as required.
 - Install clutch idler pulley assembly and torque link.
 - Install fan drive countershaft, water pump, alternator and voltage regulator.
 - Final install main rotor shaft and drive train.
 - Check belt tension, install belt tensioner, check hub to sprocket bolts and hub to shaft bolts.
- MAIN ROTOR SHAFT:** The main rotor shaft must be installed 90 degrees to the drive mount tubes in the fore and aft and lateral planes. We recommend using the digital protractor supplied, or a large builder's square (framing square), for checking squareness when installing the main rotor shaft.

3. **BEARING LOCK RINGS:** In this application the bearing lock rings must be set in the direction of rotation. This is done by using a drift punch (sized for the hole in the lock ring) and a hammer approximately 10 to 14 oz. in weight. Strike the punch in the direction the bearing will turn. (The main rotor shaft will turn clockwise viewed from above.) No more than 2 or 3 strikes are necessary to set the ring in position. Then tighten the set screw firmly. If the application requires Loctite, wait until the Loctite is dry (8 hours) before setting the lock ring. Keep in mind the larger the bearing and lock ring, the more force it will take to set.
4. **TEMPERATURE STRIP:** Check to verify that a temperature strip is installed on the upper bearing housing of the secondary unit, as shown in the photo below. (If this strip is not present, one must be installed. Contact RotorWay's parts department. To install, clean the area with acetone and apply the self-adhesive strip to the housing.)

The temp strip is a means of monitoring bearing temperatures and should be examined after every flight. The heat sensitive "dots" will darken if the indicated temperature is exceeded. During normal operation, the bearing temperature should be in the 170° to 180° range, and may be slightly higher just after adding grease. If the 200° dot darkens, it is an indication that there is a problem which is causing the bearing to run hot. If this happens, discontinue flight and contact customer service for further assistance.

The sensor for the secondary temp gauge should also be installed on the upper bearing housing. Refer to Section 21 for installation of the sensor and gauge.



MAIN DRIVE BELT CUTTING INSTRUCTIONS

1. To ensure that the main drive belts are all the same length, one wide belt is supplied. This wide belt is then cut into FOUR narrow belts, each with one groove and two peaks. To do this, make a starting cut into one of the grooves, going all of the way through. Use a utility knife with a new, sharp blade.

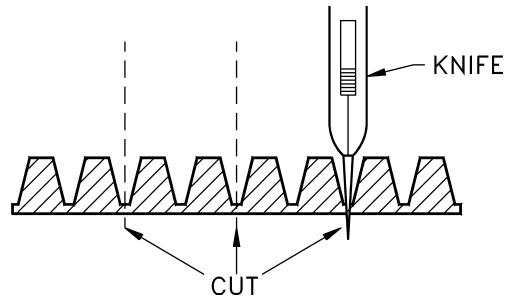

2. Remove the knife and insert it into the starting cut from the opposite side of the belt. This will allow you to see the blade and keep it centered in the groove. Have someone else pull the belts apart as you cut.

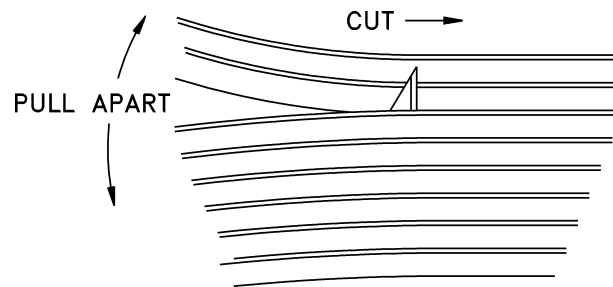

3. If needed, lightly touch the edges of the belt on a grinder or sander to remove the excess "lip". Be careful not to grind the surface of the belt that comes in contact with the pulley.



4. Repeat this process to make four equal belts.

MAIN ROTOR SHAFT INSTALLATION

Photo #1

Use prints E23-2000, E49-2000, E49-2001, and E49-2002 when installing the main rotor shaft assembly. Parts as received from RotorWay International.

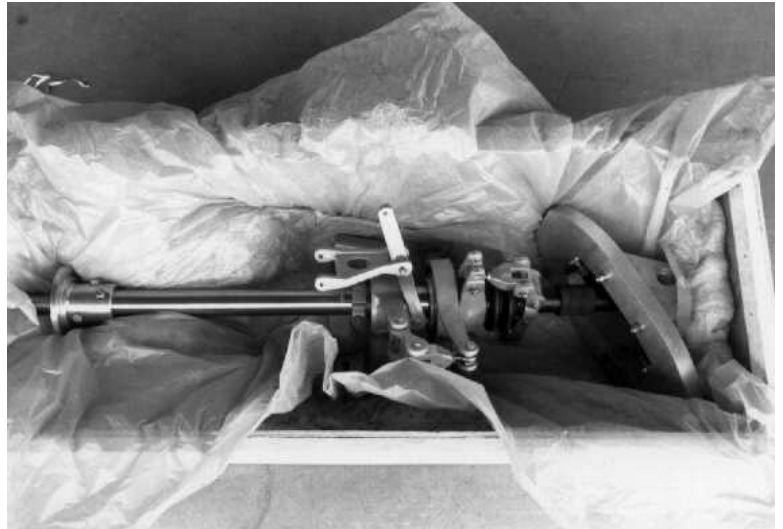

Photo #2

Install the main rotor thrust bearing and bearing flanges in the hood bracket on the airframe. The inertia switch bracket should also be installed at this time (see Section 21).

Note: Hardware and small parts for the main rotor shaft are found on E49 CARD 1 and E49 CARD 2. The inertia switch bracket and related hardware are on E25 CARD 4.

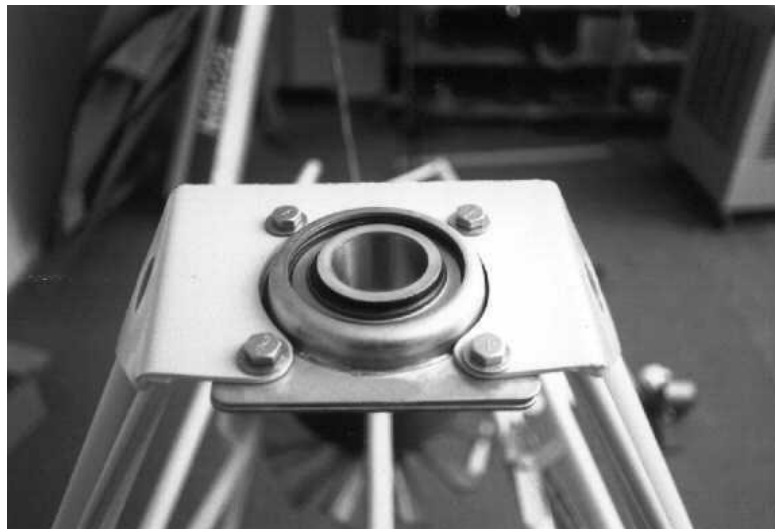

Photo #3

Clamp the upper engine mount clevis to the bottom of the square drive tubes. Place a piece of 1/8" scrap between the bottom of the square tube and the rear of the clevis. Then drill the bolt holes through the clevis, using the bushings in the airframe tubes as a guide.



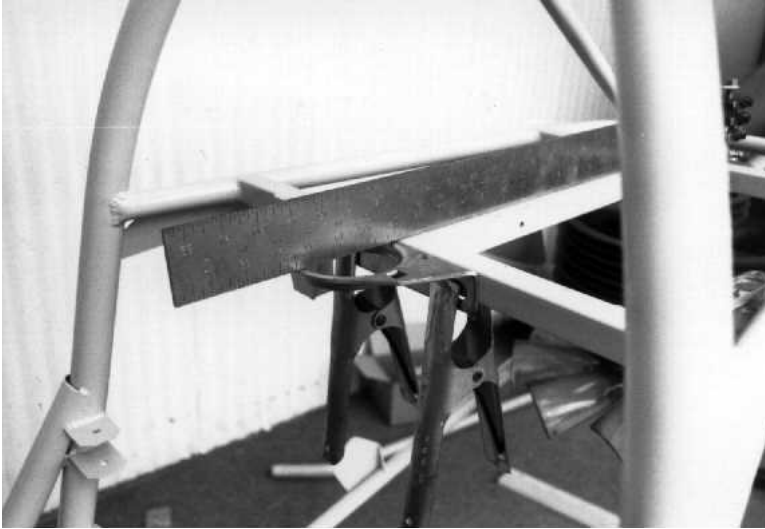

Photo #4

Clamp the flange to the front of the square drive tube on the airframe.

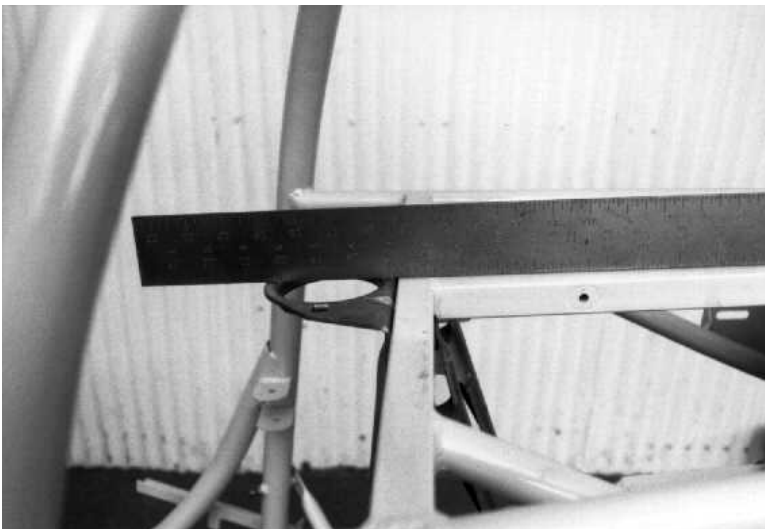

Photo #5

The top of the flange must be even with the top of the square drive tubes.

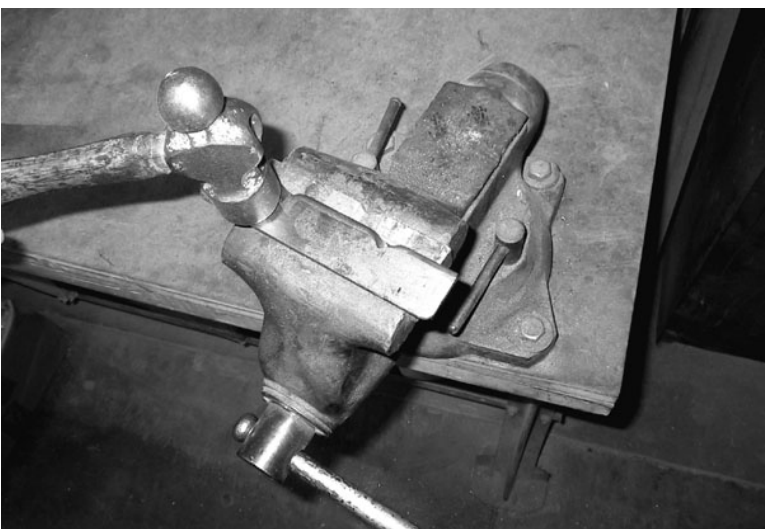

Photo #6

If the angle of the flange is not 90 degrees, clamp it in a vise and use a hammer to bend the flat part until it is at the correct angle. An alternate method is to slightly grind the flange to the correct angle, removing only as much material as is necessary.

Photo #7

Clamp the flange to the front of the square drive tube so that the tops are even. Using a felt marker, draw a line where the flange will be cut to be flush with the bottom of the square drive tube.

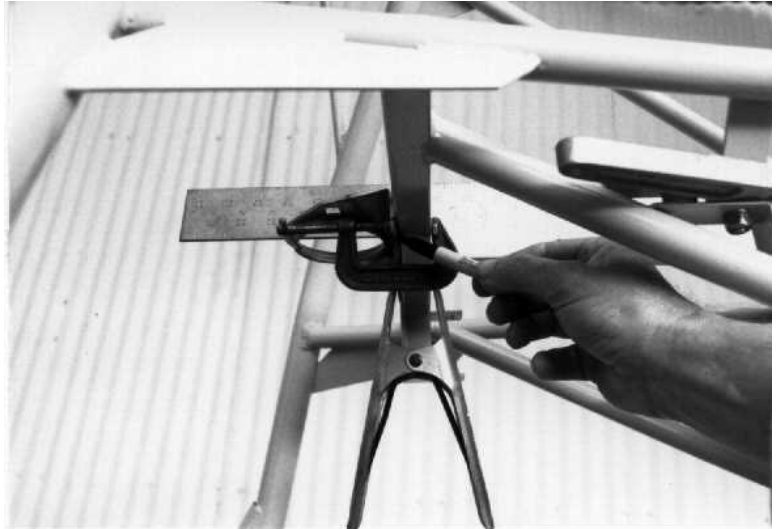

Photo #8

Transfer the mark to the other side of the flange and cut off the excess with a band saw. It is necessary to remove this excess material so the bottom of the flange will not interfere with the upper engine mount clevis.



Photo #9

Assemble the lower main shaft bearing and clamp it to the square drive tubes. Remove the sprocket hub from the main rotor shaft assembly, then install the shaft in the bearings, rotating it so that the collective actuator fork is on the pilot's side. Place a level on the square drive tubes to check the level in the fore/aft and lateral planes. Shim under the skids if necessary to level the drive tubes. Set the protractor level for 90 degrees and fasten it to the main rotor shaft. Move the lower bearing laterally until the shaft is 90 degrees to the square drive tubes. The holes in the hood bracket may be elongated if necessary to make the shaft 90 degrees to the square drive tubes fore/aft. If the main bearing flanges come into contact with the airframe tube under the hood bracket, and more adjustment is needed, the bearing flanges can be ground off slightly to allow them to be moved back.

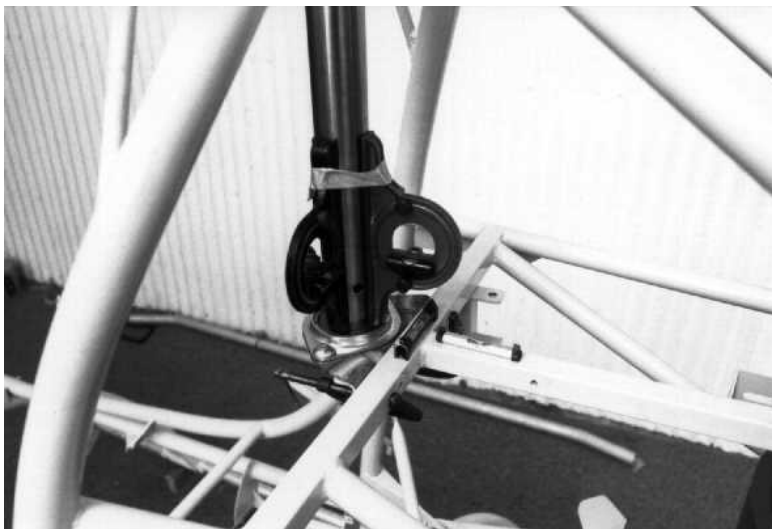

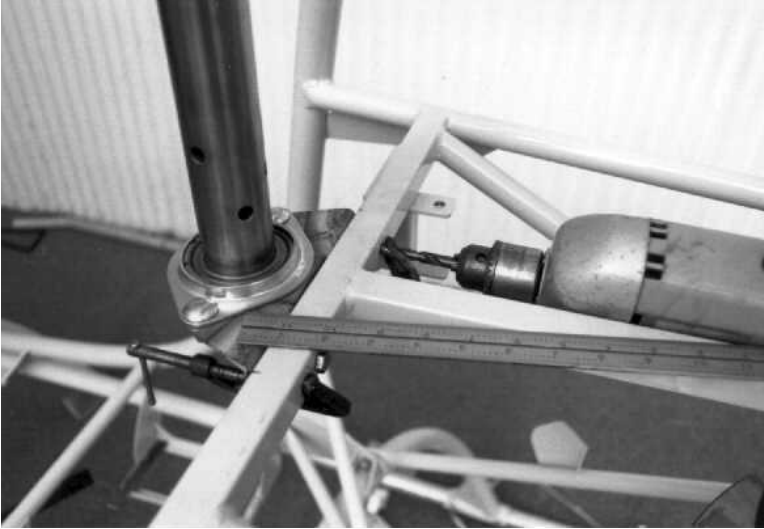

Photo #10

Check to make sure that the top of the square drive tubes and the bearing flange are even. Then drill the holes in the bearing flange using the airframe bushings as a guide.

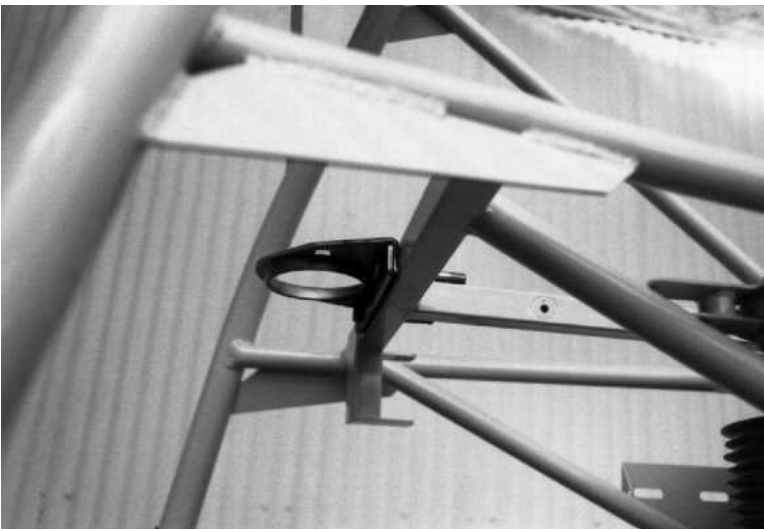

Photo #11

Check the hole alignment of the flange and square drive tube.



Photo #12

Bolt the lower bearing and upper engine mount clevis to the square drive tubes.

Photo #13

On the bottom of the sprocket hub is an index mark that matches another mark on the main rotor shaft. Using a felt-tip marker, transfer the index mark to the upper side of the sprocket hub to ensure correct alignment during re-assembly.



Photo #14

Remove the sprocket hub from the main shaft. Place the main drive sprocket on the hub.
Note: The excursion ring is held to the bottom of the sprocket with several screws. Do not remove the the ring or the screws from the sprocket.



Photo #15

Four 1/4" bolts will hold the sprocket to the hub. IT IS EXTREMELY IMPORTANT TO DRILL THESE HOLES CORRECTLY. Use a drill press to help ensure proper drilling. The holes must be drilled perpendicular (90 degrees) to the sprocket. The sprocket is pre-drilled. To transfer the holes to the hub, drill one hole through with a letter "A" drill (.234") or 15/64", then follow with a letter "D" drill (.246"). Insert a 1/4" bolt in the hole to hold alignment, then drill the remaining holes in the same manner.

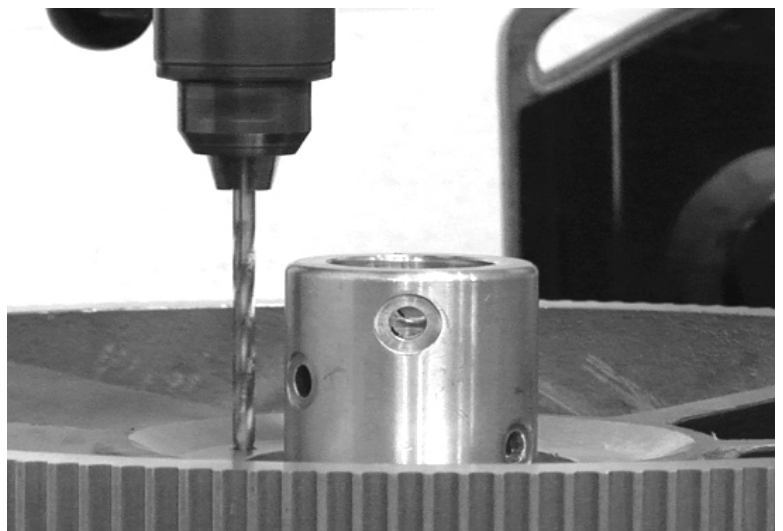

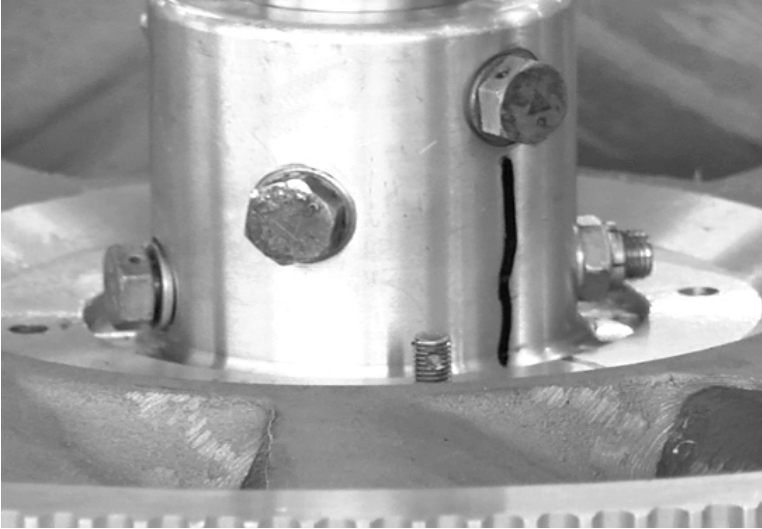

Photo #16

Raise the main shaft and install the sprocket and hub onto the shaft. Make sure that the locking ring is in place, but not locked, on the upper main shaft bearing.

Install the 3/8" bolts that hold the sprocket hub to the main shaft. The lowest bolt should be installed first, and the sprocket must be raised to install it (see next photo).

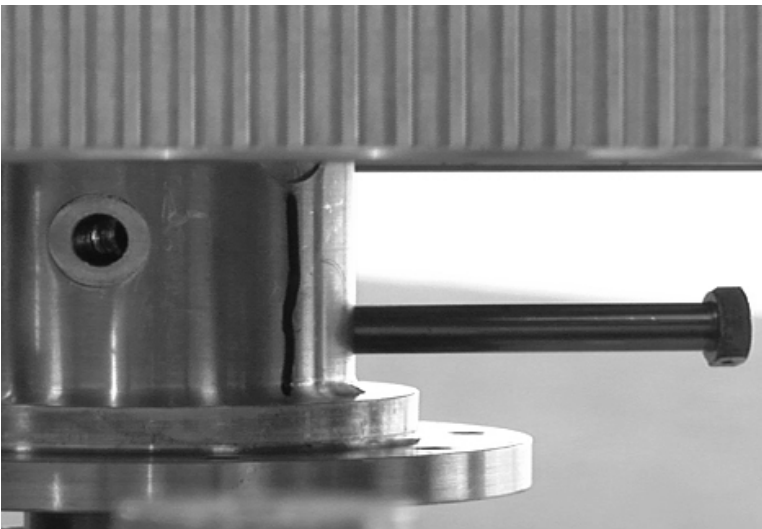

Photo #17

To install the lowest bolt, raise the sprocket above the hub, and insert the bolt from below. Then lower the sprocket and install remaining hardware.

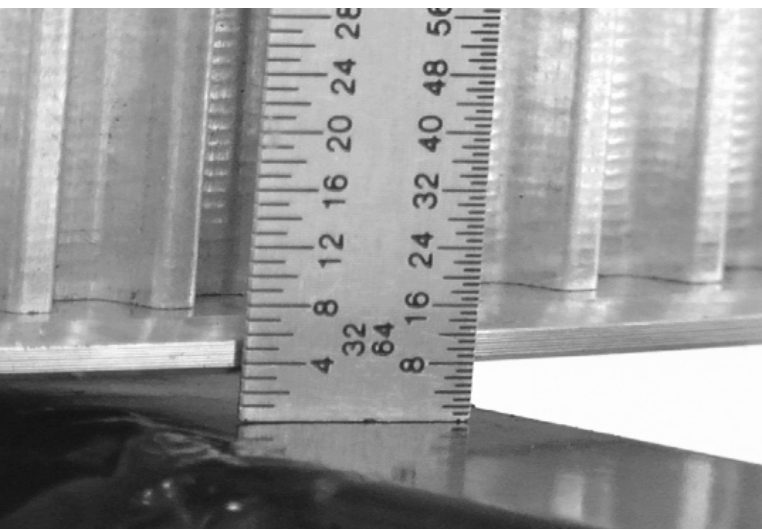

Photo #18

Check the height between the bottom of the sprocket to the top of the square drive mount tubes. The correct height should be 1/4 inch. In this photo the sprocket is too low and must be raised.

Photo #19

The sprocket can be raised by lifting the main rotor shaft and placing washers (maximum of 3), part number E00-4851, on top of the inner race of the lower main shaft bearing.

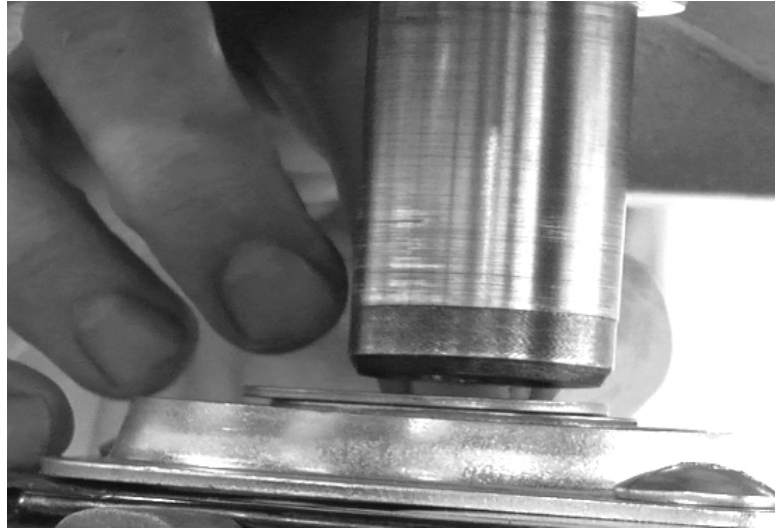

Photo #20

Install the sprocket to hub bolts from the bottom using a washer under each bolt head, and a combination of one or more washers under each nut to properly locate the nut. (Use 1/4" all metal thin locknuts, part no. E00-3410). These bolts should fit snug enough that it will be necessary to lightly tap them in place with a plastic hammer.

Torque the 1/4" bolts to 7 ft. lbs. Safety wire the bolts, wiring the heads to each other and the shanks to each other.

Torque the 3/8" bolts to 18 ft. lbs. Safety wire the bolts together as shown.

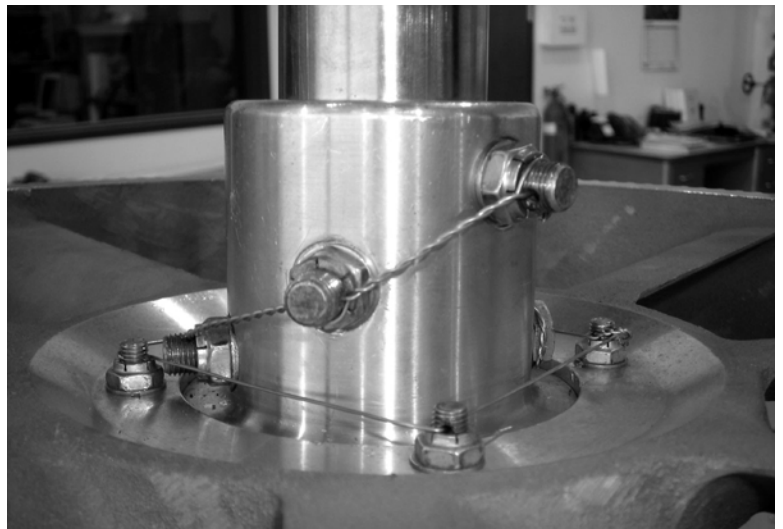
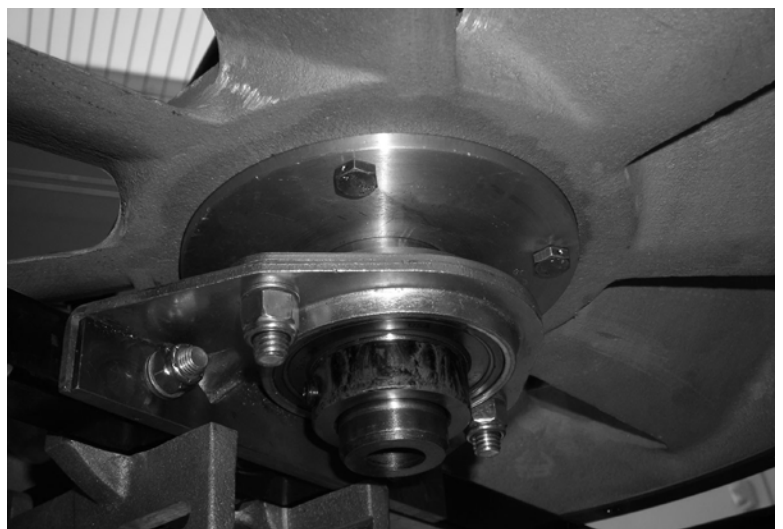

Photo #21

On final assembly, use Loctite #609 to secure the lower main shaft bearing to the shaft. Allow the Loctite to set at least 8 hours, then tighten the two set screws on the inner bearing race.





SECONDARY DRIVE INSTALLATION

Photo #22

Use print E23-2000 and template E23-1 when assembling the secondary drive. Parts as received from RotorWay International.

Before installation, remove the following from the secondary drive assembly:

1. The tail rotor drive pulley and related hardware.
2. The lower bearing and flanges.

Photo #23

It is critical that the upper bearing, aluminum housing and rubber seals do not pivot on the shaft during installation. They must be held in alignment with the shaft to prevent damage to the bearing and to keep the seal from leaking. To do this, install spacers or shims between the bearing housing and the auxiliary drive pulley as shown by the arrows. The spacers should fit snug and must be equal thickness on both sides of the pulley to ensure correct alignment.

Install the secondary assembly, centered on the airframe tube.

Note: The main drive belts, upper fan drive belt and alternator belt must also be installed at this time.

Photo #24

Level the airframe fore/aft and laterally at the square drive mount tubes by shimming under the skids as necessary. For the secondary assembly to be installed correctly, the following conditions must be met when the upper bolts are tight:

1. The secondary shaft should be tilted .1 degree (one tenth of a degree) towards the rear and .1 degree towards the pilot's side, compared to the main rotor shaft.
2. The upper bearing housing of the secondary assembly must be perpendicular (90 degrees) to the secondary shaft. The flat surface under the grease fitting can be used to verify alignment of the upper bearing housing. (Unscrew the grease fitting and remove any burrs on the edge of the threaded hole. The end of the level can then be placed against the flat surface.)

Note: A digital protractor works best for this installation. For accuracy, the same level should be used for all measurements.

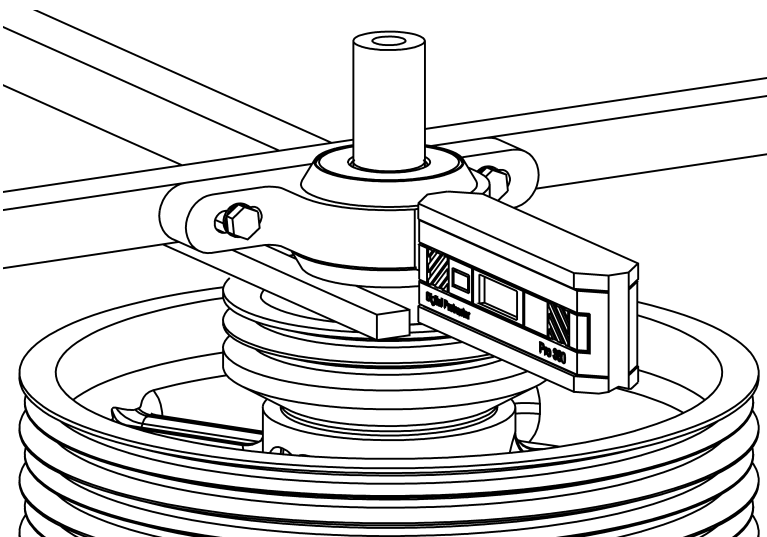
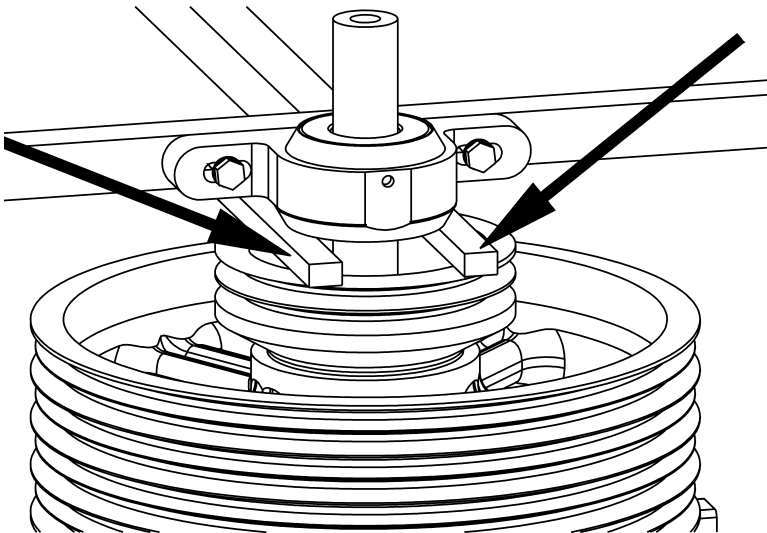

Photo #25

If necessary, the angle of the upper bearing mount can be modified by filing or sanding the angle of the mounting surface.

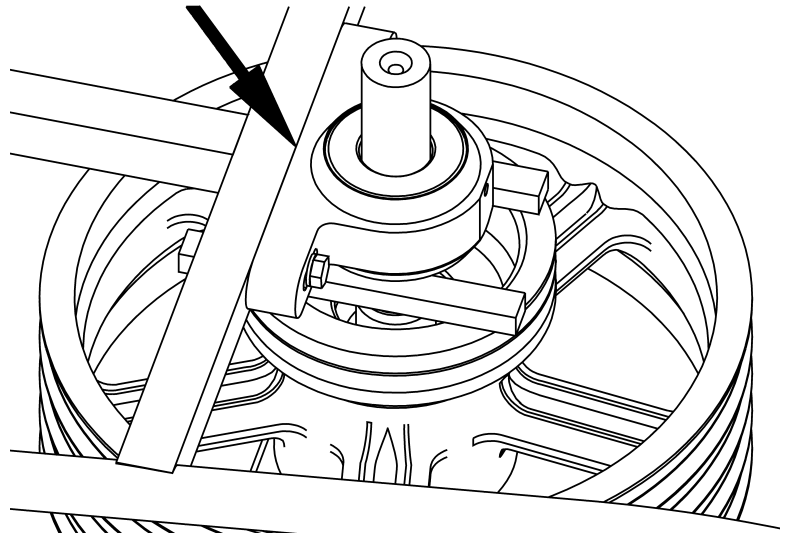

Photo #26

Install the lower bearing and flange on the shaft. Use the lock ring on the bearing to hold the flange in the proper up or down location. The top of the flange should be approximately even with the top of the square tube. When the flange is in the right position, tighten the two clamping bolts that hold the halves of the flange together. If there is any gap between the flange and the airframe, install shims as required to achieve a snug fit. **DO NOT TRY TO ELIMINATE THE GAP BY TIGHTENING THE BOLTS.** After the shims are in place, install and tighten the mounting bolts.

WARNING: Any misalignment of the upper bearing to the shaft may result in failure of the assembly.



Photo #27

When installation is complete and all bolts are tight, the final position of the secondary shaft, pulley and upper bearing mount must be .1 degree tilted aft and .1 degree tilted to the pilots side. This ensures good belt tracking.

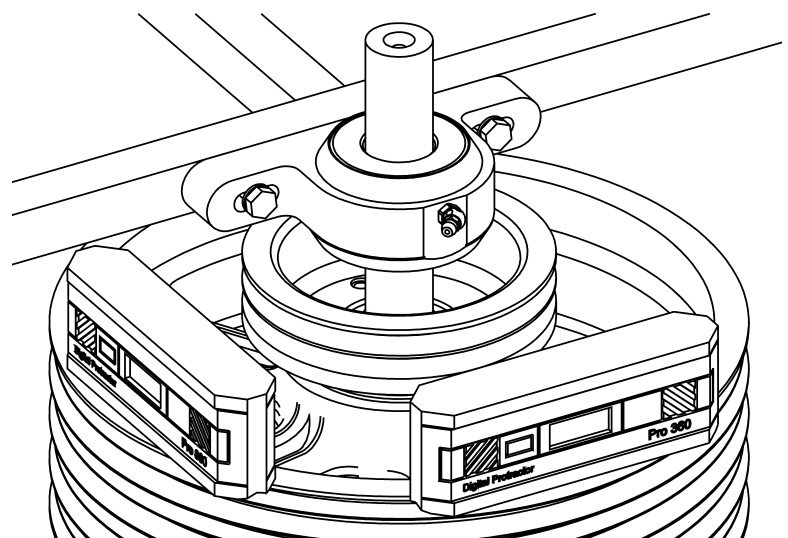



Photo #28

Make sure that the vertical position of the lower bearing and flange will allow enough clearance for the tail rotor drive pulley to be installed. The bearing and flange can be moved up if necessary. On final assembly, Loctite the lower bearing to the shaft. Set the lock ring and tighten the set screw.

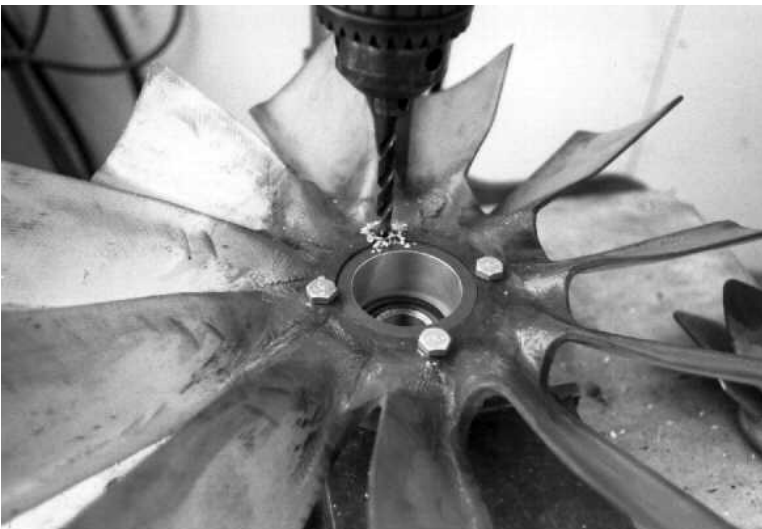

Photo #29

Lay out the bolt holes for mounting the fan to the pulley. The fan should be installed "smooth side up". Make sure it is positioned correctly before drilling the holes.

Place the pulley and fan on a drill press and drill one 1/4" hole. Install a bolt then drill another hole. Repeat this procedure until all holes are drilled and all bolts are installed.

Note: Install each bolt with a 1/4" large washer between the head of the bolt and the fiberglass fan, and a 1/4" regular washer between the nut and the aluminum pulley.



Photo #30

This shows the installation of the tail rotor drive pulley and fan assembly on the lower end of the secondary shaft.

Note: Final installation of the tail rotor drive pulley and the fan assembly must be done AFTER the radiator and fan shroud are installed (see Section 18). On final installation, the fan pulley bearing must be Loctited to the secondary shaft. Allow time for the Loctite to cure, then tighten the two set screws.

Photo #31

The locking assembly is a device that prevents the secondary sprocket from turning on the shaft. It **MUST** be installed according to these instructions to ensure that it will work properly. Handle the unit carefully to avoid nicks and scratches.

Before installation, check all contact surfaces of the locking assembly. They must be clean and lightly oiled. This includes the screw threads and screw head bearing surfaces.

Note: Do not use Molybdenum Disulfide, "Molykote" or any other similar lubricants.

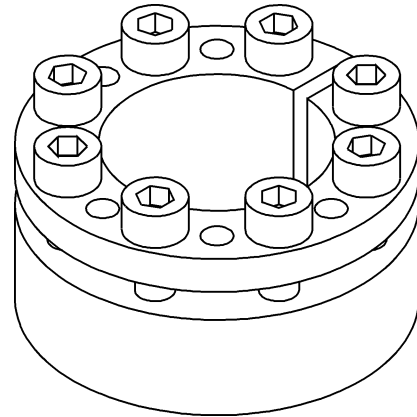

Photo #32

Back off all locking screws. Remove 2 screws opposite from each other and insert them into the adjacent push-off threads. Turn them by hand until they make contact. This will keep the locking assembly spaced apart. Insert the locking assembly into the sprocket bore. If necessary, back off the locking screws more and tighten the push-off screws until it fits. This is a very close fit. After the locking assembly is inserted, return the push-off screws to their original holes.

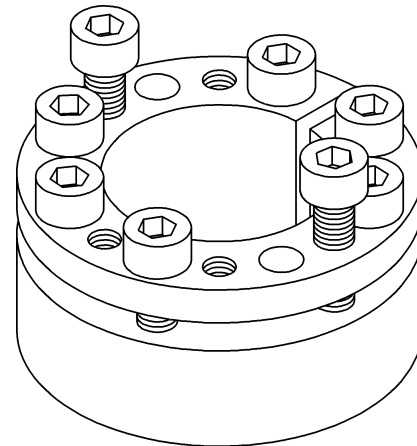
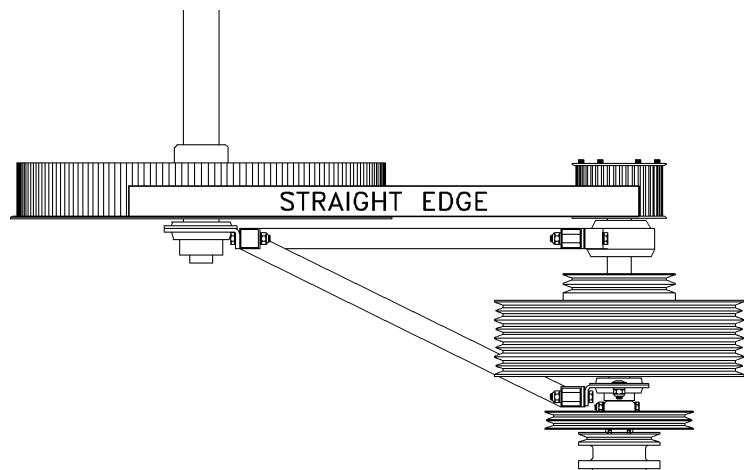

Photo #33

Install the sprocket on the secondary shaft. Align the sprocket with the main sprocket using a straight edge as shown. When installed and all bolts tightened, the height of both sprockets should be the same. This is measured at the bottom excursion rings of both front and rear sprockets.

Note: While the locking bolts are being tightened, the locking assembly and sprocket may have a tendency to raise, which will affect alignment. Observe the amount of lift and re-adjust if necessary. (It is common to see about .025 inch lift.)



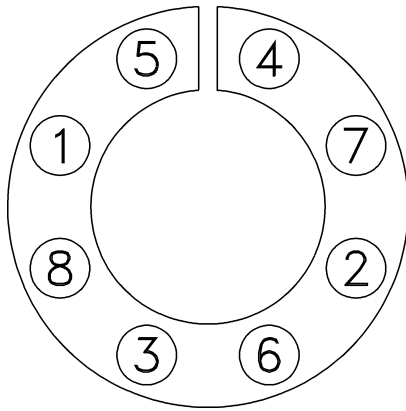

Photo #34

Hold the sprocket and the locking assembly in the desired position up against the retainer plate, and begin tightening the screws. The screws must be tightened gradually and in several stages, using the tightening sequence shown. The bolts must be torqued to 10 ft. lbs.

Note: As described above, the locking assembly and sprocket may have a tendency to raise while the bolts are being tightened. Height must be verified after the bolts are torqued.

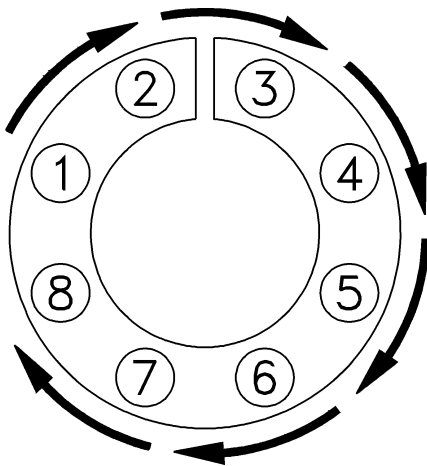

Photo #35

After installation is complete, check torque of the screws again in a clockwise or counter-clockwise sequence. Make sure that none of the bolts can be turned at 10 ft. lbs.

Note: After the first hour of operation, re-check the torque of these bolts. If any looseness is detected, re-check the torque at subsequent intervals until the bolts remain tight.

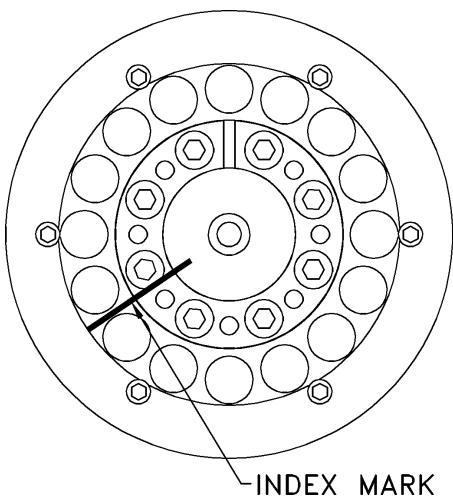

Photo #36

Make an index mark on the sprocket and locking assembly with dye or a permanent marker. Although it is very unlikely that the locking assembly will slip, this will indicate if it does.

Photo #37

If it becomes necessary to remove the locking assembly in the future, first loosen all screws 2 turns, then remove them and transfer them to the push-off threads. Progressively tighten the screws, using the tightening sequence shown, until the assembly is released.

