

Section 18

Cooling System

Procedures covered in this section:

Fit and install fan shroud to radiator; install radiator; fit and install fan shroud ring; install cooling system hoses and components; install surge tank; fabricate sump strap and install oil sump/heat exchanger; install hose jackets and oil lines.

Cards used in this section:

HARDWARE CARD	E28 CARD 1	E34 CARD 1	E34 CARD 3
E25 CARD	E30 CARD 1	E34 CARD 2	

Prints used in this section:

E30-2000	E37-2000
----------	----------

Templates used in this section:

None

Tools required for this section:

Air or electric drill	Cleco pliers	Hammer	Screwdrivers
Band saw or hacksaw	Files	Level	Snap ring pliers
Cleco	Grinder	Metal cutting snips	Tape measure

Drill bits of the following sizes: 1/8", 3/16", 1/4", 5/16", #40
Ratchet with sockets of the following sizes: 5/16", 3/8", 7/16", 1/2"
Wrenches of the following sizes: 5/16", 3/8", 7/16", 1/2", 13/16", 7/8"

Notes:

1. FAN: Remove the tail rotor drive pulley from the secondary shaft, if installed. Slide the fan and pulley assembly onto the secondary shaft. The fan should be mounted on the pulley "smooth side up". DO NOT use Loctite on the bearing at this time, because the fan assembly must be free to slide up and down on the shaft during fan shroud installation. Install the snap ring on the shaft to temporarily hold the fan assembly in place.

After the shroud is fitted as shown in this section, remove the fan assembly and install the tail rotor drive pulley. Then final install the fan and pulley assembly, using Loctite between the bearing and the shaft. Allow time for the Loctite to cure, then tighten the two set screws. (Refer to Section 11.) Install the snap ring on the shaft.

2. OIL HOSES: Before installing the hoses, flush them thoroughly with solvent and blow them dry with compressed air. Carefully inspect the insides of the hoses for any dirt or debris. Apply a light film of engine oil to the threads and chamfers of the fittings. Route the hoses so that they curve smoothly without being kinked or sharply bent. The aluminum hose ends and fittings can be damaged if over tightened. To get the right amount of leverage, grip the wrench about 3 or 4 inches from the fitting.

Before installation, all braided oil and fuel hose should be covered with hose jackets (see E25 CARD 4). Cut the material to the right length, slide it over the hose and secure both ends with hose jacket tape. If necessary, a hose end can be removed to make installation easier, then replaced after the hose jacket is installed.

3. AIR BLEED VALVE: The air bleed valve on the waterjacket elbow (on top of the engine, passenger side) is for bleeding the air out of the cooling system during the first start-up. See the Engine Manual for details.

PREFACE

One of the biggest obstacles in keeping your aircraft's engine cool is heat recirculating in and behind the engine compartment. In forward flight the air scoops supply plenty of outside air to the fan, but in a hover, adequate cooling can be more difficult.

The cooling fan pulls air from the area above and around it and pushes it through the radiator. During construction of your aircraft, or if you ever encounter cooling problems, look carefully at the areas from which air is being drawn. The exhaust system radiates the majority of the heat, so fabricate the heat shielding to fit as close as possible around the exhaust pipes and out to the body panels.

The engine cooling system and the oil sump/heat exchanger have been designed for maximum performance, light weight, and longevity. Because of the efficiency of this integrated cooling system, you will discover that the operating temperature is attained within minutes and the correlation of oil and coolant temperatures is very consistent.

RADIATOR

Photo #1

Use prints E30-2000 and E37-2000 when installing the cooling system components. Radiator with mounting bolts, rear mounting straps, and shroud attachment bolts.

Note: If your helicopter is equipped with the optional Altitude Compensation Induction System, the ACIS oil cooler should be installed at the same time as the radiator and fan shroud. Refer to Section 27 for ACIS instructions.

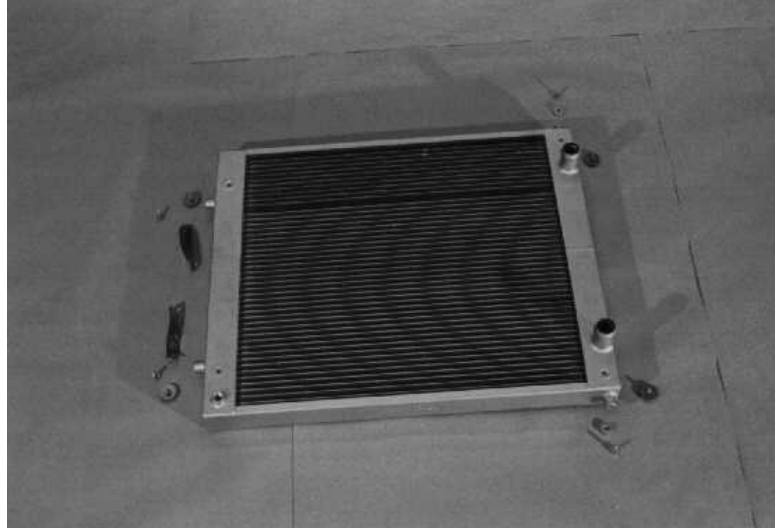

Photo #2

Fiberglass shroud and ring.



Photo #3

Overview of the fiberglass shroud and ring mounted on the radiator with the aluminum exhaust heat shielding attached. The radiator rear shield is shown detached at left.

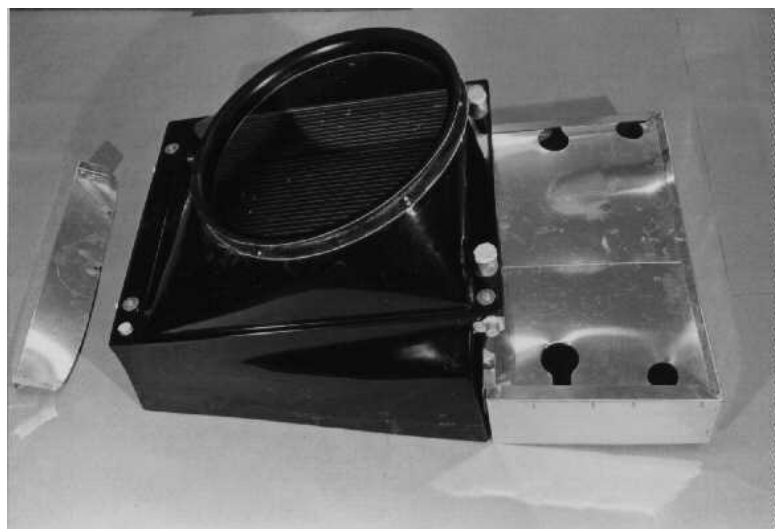

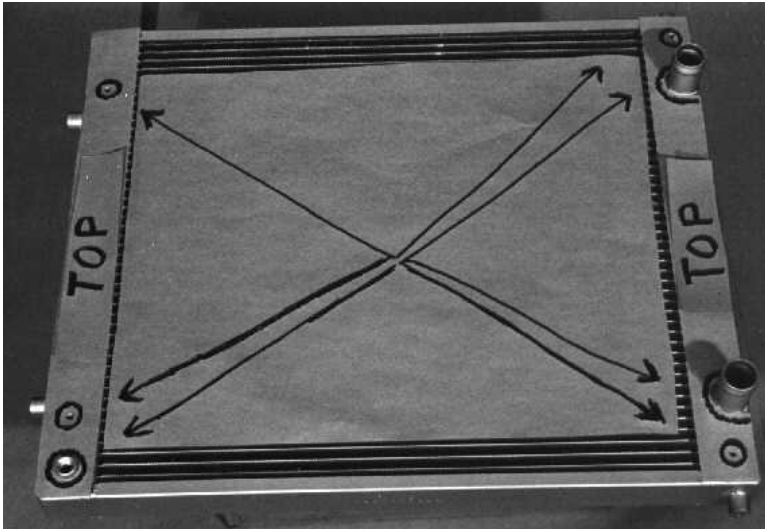

Photo #4

Place the radiator with outlets facing up on a sturdy cardboard box. (The box should be just smaller than the radiator and at least 10" high.) Make two paper templates to help layout the seven hole locations as shown. Label both templates top and bottom.

Note: Leave the cardboard covers on the radiator core for protection until final installation.

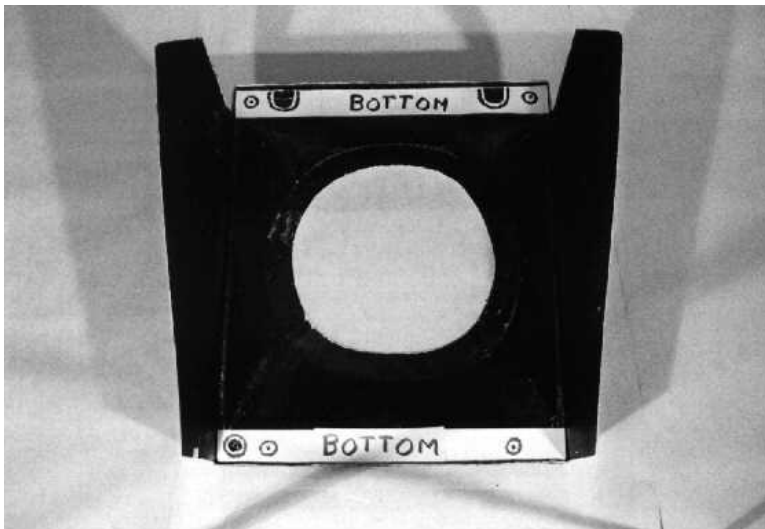

Photo #5

Place the shroud upside down next to the radiator. Flip the templates into the shroud. Measure each hole centerline from the edges of the radiator and from tank to tank. Align the templates accordingly and tape them down.



Photo #6

Drill small pilot holes (about 1/8") and re-check your layout. Minimum finished hole diameters are as follows:

- | | |
|-----------------------|--------|
| Inlet and outlet: | 1-5/8" |
| Four shroud mounts: | 17/64" |
| Air bleed valve hole: | 1-1/8" |

Start small and re-check often for a good fit.

Photo #7

Be sure the fiberglass clears the welds around the 3 ports.



Photo #8

Tape the ports shut to prevent any debris from entering. Attach the shroud to the radiator using 1/4-20 x 5/8 bolts and fender washers.



Photo #9

The engine (with exhaust pipes) and the secondary must be in their final locations.

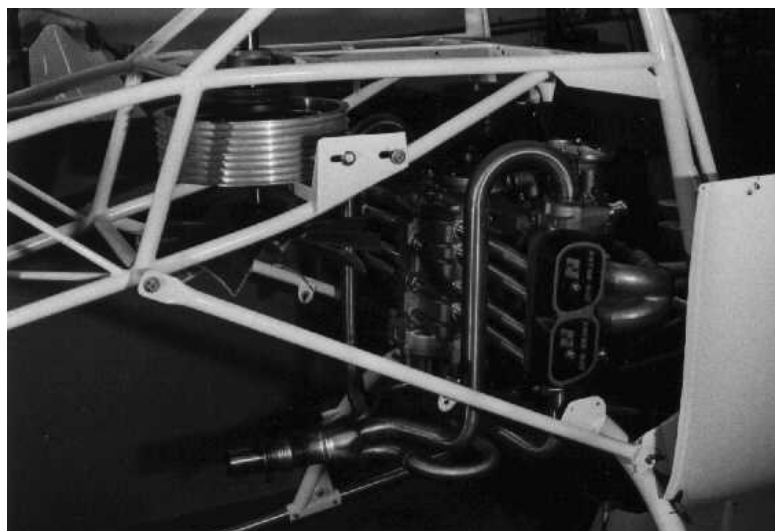

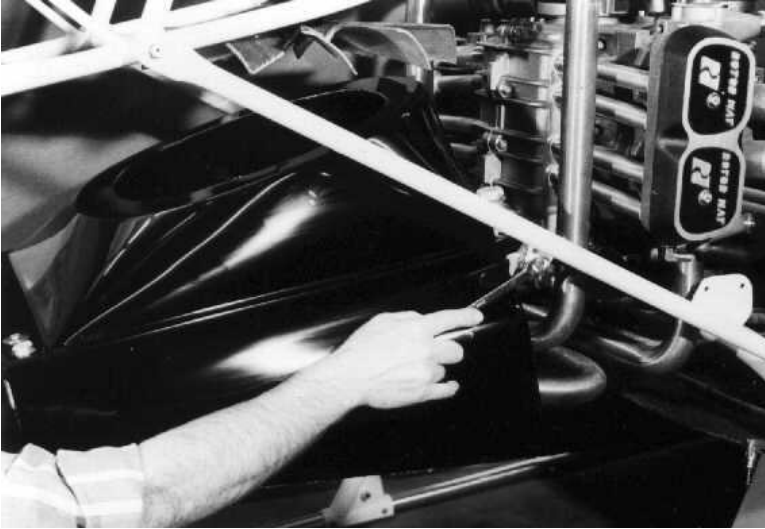

Photo #10

Install the radiator and shroud using 1/4-20 x 3/4" bolts. Use a 1/4" aluminum spacer between each airframe bracket and the radiator. Temporarily support the rear of the radiator by wiring it to the airframe.



Photo #11

Raise the radiator until the top of the shroud is parallel with the fan. The fan should be able to slide up the shaft as the radiator is raised.

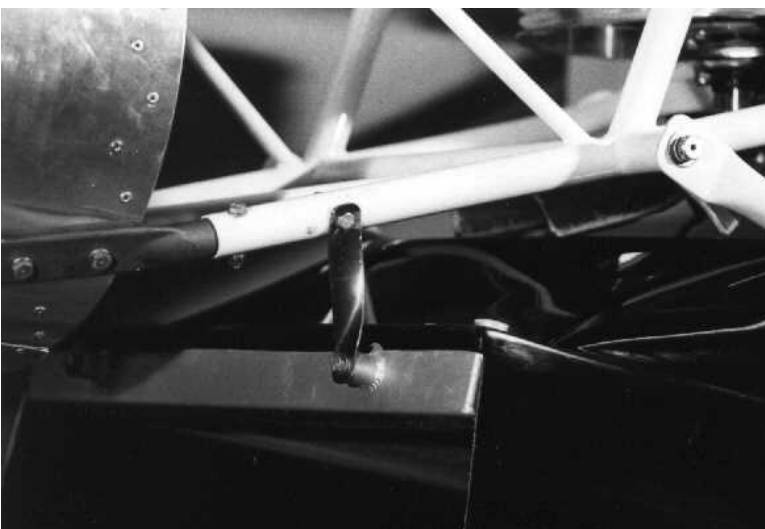

Photo #12

Fabricate the rear radiator mounts from 3/4" x .063 steel strap. These must be twisted approximately 90 degrees. Use the forward tail boom attachment bracket bolts to secure the straps to the airframe.

Photo #13

The fan must contact the shroud evenly. Select one blade that contacts the shroud and use it as a guide to scribe 360 degrees for the fan opening.



Photo #14

Sand off any excess resin on the inside diameter of the fan shroud ring.

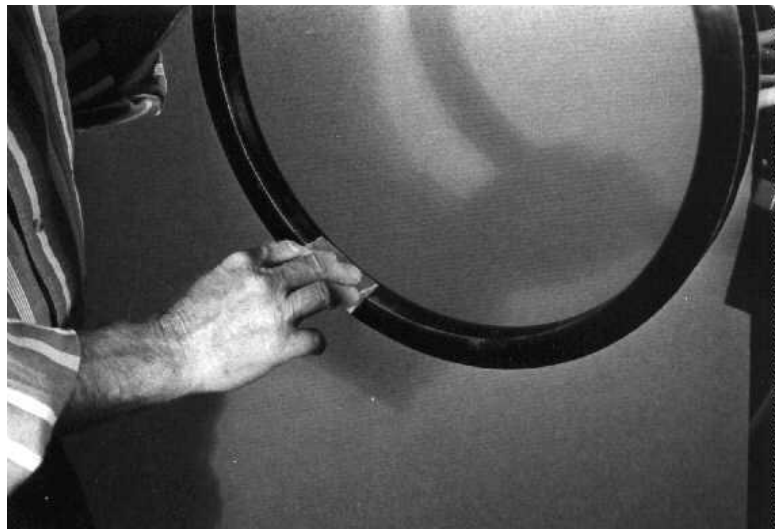

Photo #15

Remove the radiator from the airframe and put it on the box. Tape the ring onto the shroud with the flat side down and concentric to the scribed circle. Scribe the inside diameter of the ring onto the top of the shroud. Then cut just outside of the scribed circle. Adequate fan clearance within the shroud now will permit the ring to be relocated later, if adjustment of the secondary drive unit is necessary.





Photo #16

Re-install the radiator and shroud. Clamp the ring so that it is concentric with the fan. The top of the fan should be flush with the top of the ring. The radiator and shroud can be lifted higher at the rear to achieve this.

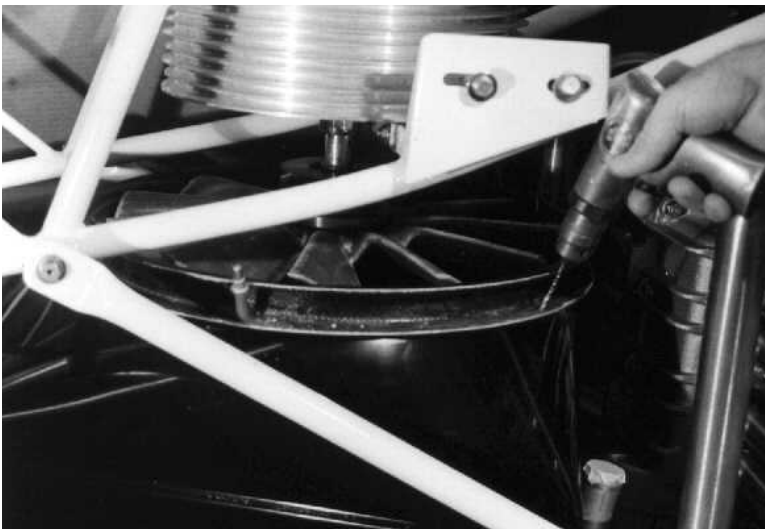

Photo #17

Drill two 1/8" rivet holes on each side, being sure to intersect the shroud. Insert a cleco in each hole as you go.

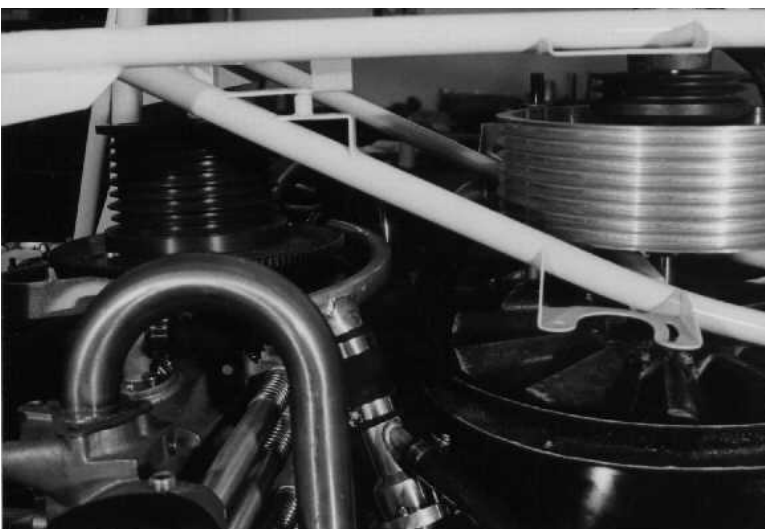

Photo #18

Remove the radiator and shroud and finish drill 8 rivet holes through the ring and shroud. Remove the ring. Squeeze a narrow bead of silicone sealant where the parts will be joined, intersecting the rivet holes. Pop rivet the shroud and ring together. Note: The 1/8" to 3/16" clearance between the fan and ring, as indicated on print E30-2000, MUST be maintained around the entire fan. Trim the fan if necessary to provide this clearance.

COOLING SYSTEM

Photo #19

Overview of cooling system components. At left: 120 degree manifold, water tees. At right: air bleed valve, surge tank.

The air bleed valve, found on E29CARD1, is used on the 120 degree manifold. Use Teflon tape on the threads when installing.



Photo #20

Water tees used on pilot and passenger sides are identical. Inside the tee, the smaller tube is cut at an angle to improve flow in the desired direction. Install them as shown.

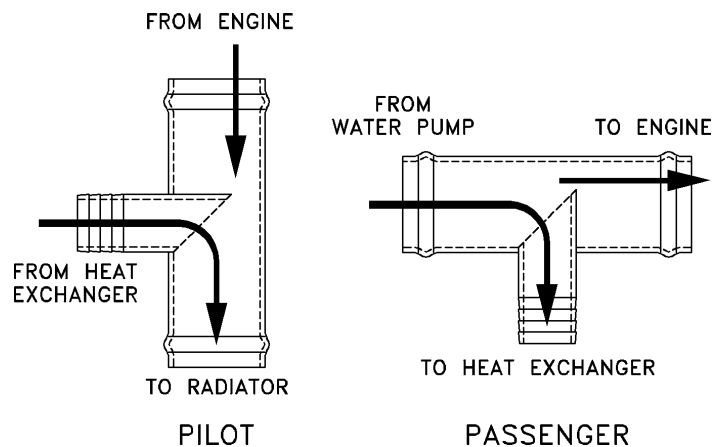

Photo #21

Coolant hoses, passenger side. Install the lower hose first. Trim to fit. Install the 120 degree manifold and remaining hoses according to print E30-2000. The two long sections of straight hose, part number E34-8120, will make all of the short hoses here and on the pilot's side.

The 3/4 hose from the 120 degree manifold goes to the surge tank.



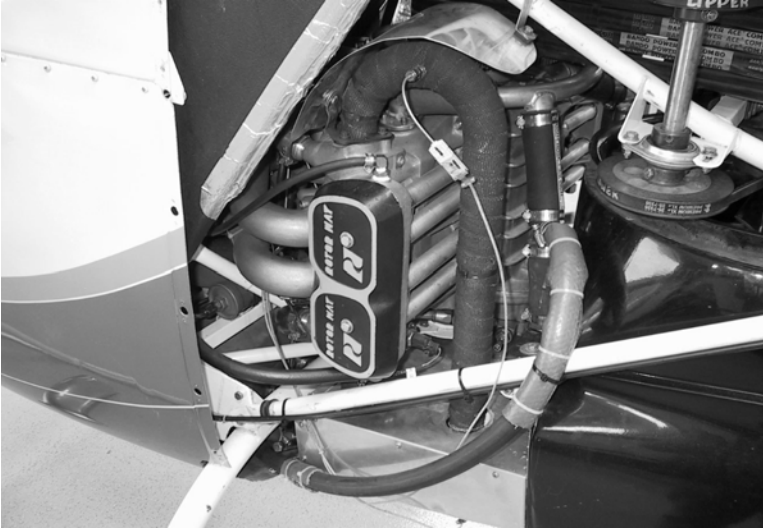

Photo #22

Install hoses on pilot's side. Route hose from the heat exchanger to the "T", avoiding exhaust pipes as shown. Use firesleeve as needed.



Photo #23

If necessary, adjust the bottom coolant hoses on the engine (from the cylinder head to the waterjacket) to avoid contact with the engine mount. Both hoses are covered with firesleeve for protection from adjacent exhaust pipes.

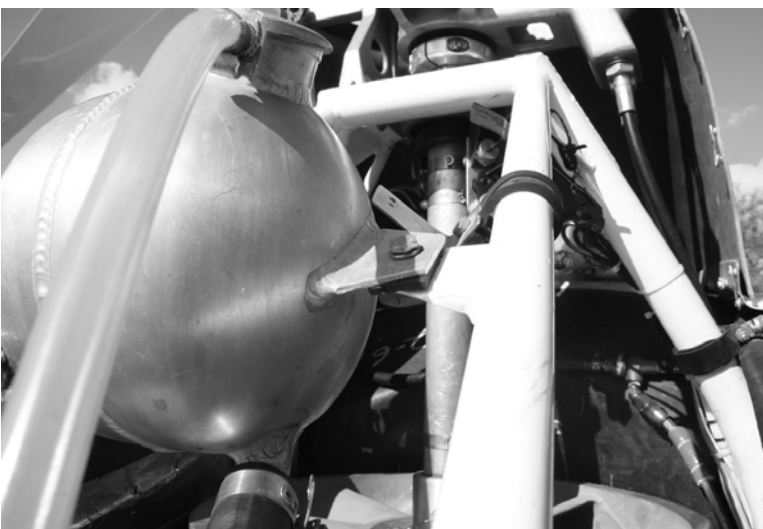

Photo #24

Locate the surge tank on the airframe brackets. To isolate the tank from vibration, use rubber stripping between the mounting ears of the tank and the airframe brackets. Drill 3/16" bolt holes in the brackets (if not already there) and 1/4" bolt holes in the ears of the tank. Install the tank using 3/16" bolts, nuts and washers.

Route the overflow hose so that it will drain behind the radiator. The 3/4 inch hose connects to the 120 degree manifold.

OIL SUMP

Photo #25

Overview of the sump mounting strap. It will attach to the engine mount bolt on the pilot's side, and to the short square tube extending from the fuel system mount tube on the passenger side.

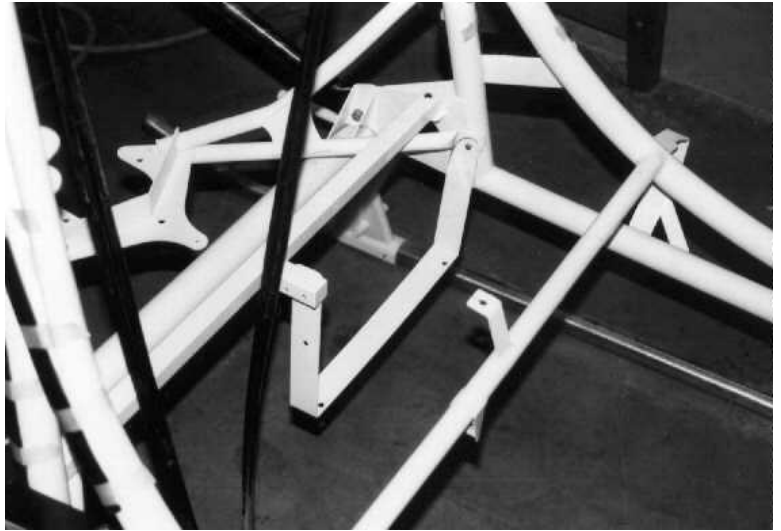

Photo #26

Fabricate the sump mounting strap as shown. Glue rubber strips to the strap where it contacts the sump. Drill the 1/4" holes for the bolts that attach the strap to the sump. DO NOT drill the 3/16" bolt holes yet. Bolt the strap to the sump and place the assembly on the airframe.

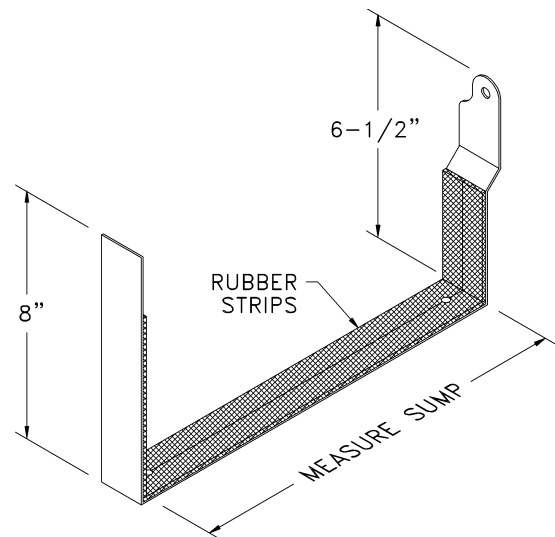

Photo #27

When installed, the sump must be level from side to side, and tilted so that the front is 1/2" higher than the back. It must not come in contact with the fiberglass tub. Drill the 5/16" hole in the strap on the pilot's side and attach it to the engine mount bolt. Adjust the sump to the correct position, clamp the strap in place, and drill the 3/16" bolt holes. After drilling, install the bolts.

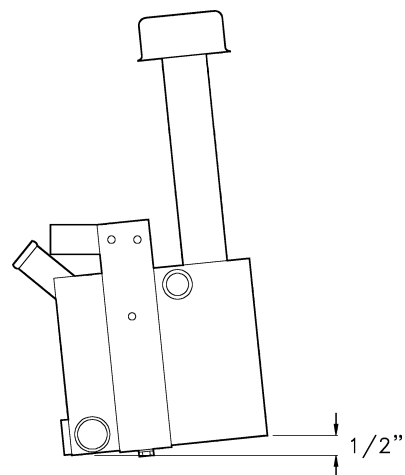



Photo #30

All braided hoses should be covered with hose jackets, supplied on E25 CARD 4. Cut the material to the right length, slide it over the hose and secure both ends with hose jacket tape.

Note: The fittings on these hoses are aluminum and can be damaged if over-tightened.

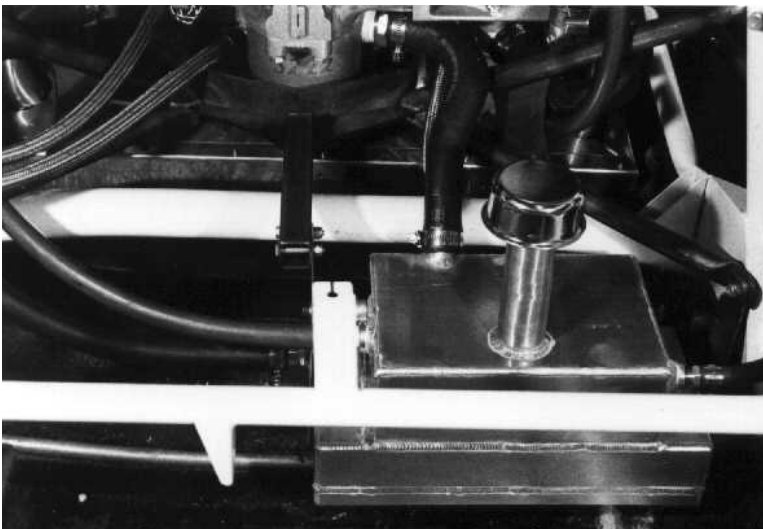

Photo #31

Install the hoses. The large 1" hose that bends 90° is the main oil drain hose, from the engine to the oil sump tank. The small 1/2" hoses on both sides of the tank near the top, are rocker box oil drains.

Note: If equipped with optional ACIS, install ACIS oil hoses according to instructions in Section 27.

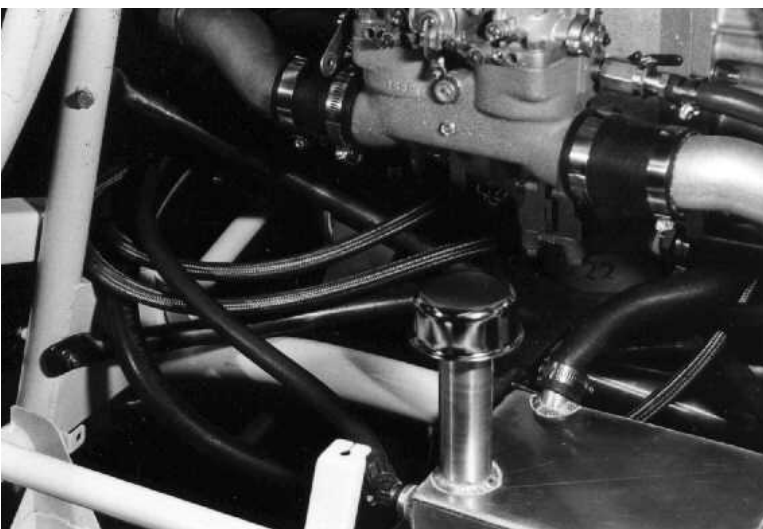

Photo #32

Partial view of the three braided steel oil lines. The hose on the far right routes from the oil sump to the oil pump inlet on the engine (90° fitting). The middle hose routes from the oil pump outlet (45° fitting in oil pump cover) to the "in" port of the oil filter. The hose on the left is from the oil filter "out" to the engine.