

Section 13

Tail Rotor Drive

Procedures covered in this section:

Install driveshafts and gearboxes; install drive belt and tensioner; fabricate and install tail rotor pitch actuator arms; install tail rotor control cable; fit tail rotor blade tip caps; assemble and balance tail rotor; install carriage slider; install tail rotor shaft into gearbox; measure and install slider to actuator arm clevis; fit and install tail cone cover and slider cover.

Cards used in this section:

HARDWARE CARD E18 CARD 1
E16 CARD 3 E18 CARD 2

Prints used in this section:

E09-2000 E17-2001
E17-2000

Templates used in this section:

E18-1

Tools required for this section:

Band saw	Mallet	Snap ring pliers
Drift punch	Pliers	Tape measure
Hammer	Protractor level	

Ratchet with sockets of the following sizes: 3/8", 7/16", 1/2", 9/16", 11/16"

Wrenches of the following sizes: 3/8", 7/16", 1/2", 9/16", 11/16"

Notes:

1. **TAIL ROTOR CONTROL CABLE ROUTING:** The drawing below shows an overall view of the installation of the tail rotor control cable.

When routing the tail rotor cable, start at the tail end and work forward. This way you can pull the slack out of the tail boom end and leave it in the tub. Run the cable under the horizontal fin spar (A) and along the bottom of the tail boom. Use plastic wire ties to attach it to the bulkheads. Moving forward, attach the cable along the left of the ballast weight weldment (B).

As the cable leaves the boom, route it under the cross brace and lower tailboom mount tube (C). This will reduce a tight radius area. Then run it along the outside of the tailboom support tube, pilot side (D), above the rear landing gear (E) and under the fuel tank (F). The cable will last longer if it is not tied in a tight radius anywhere along the cable path.

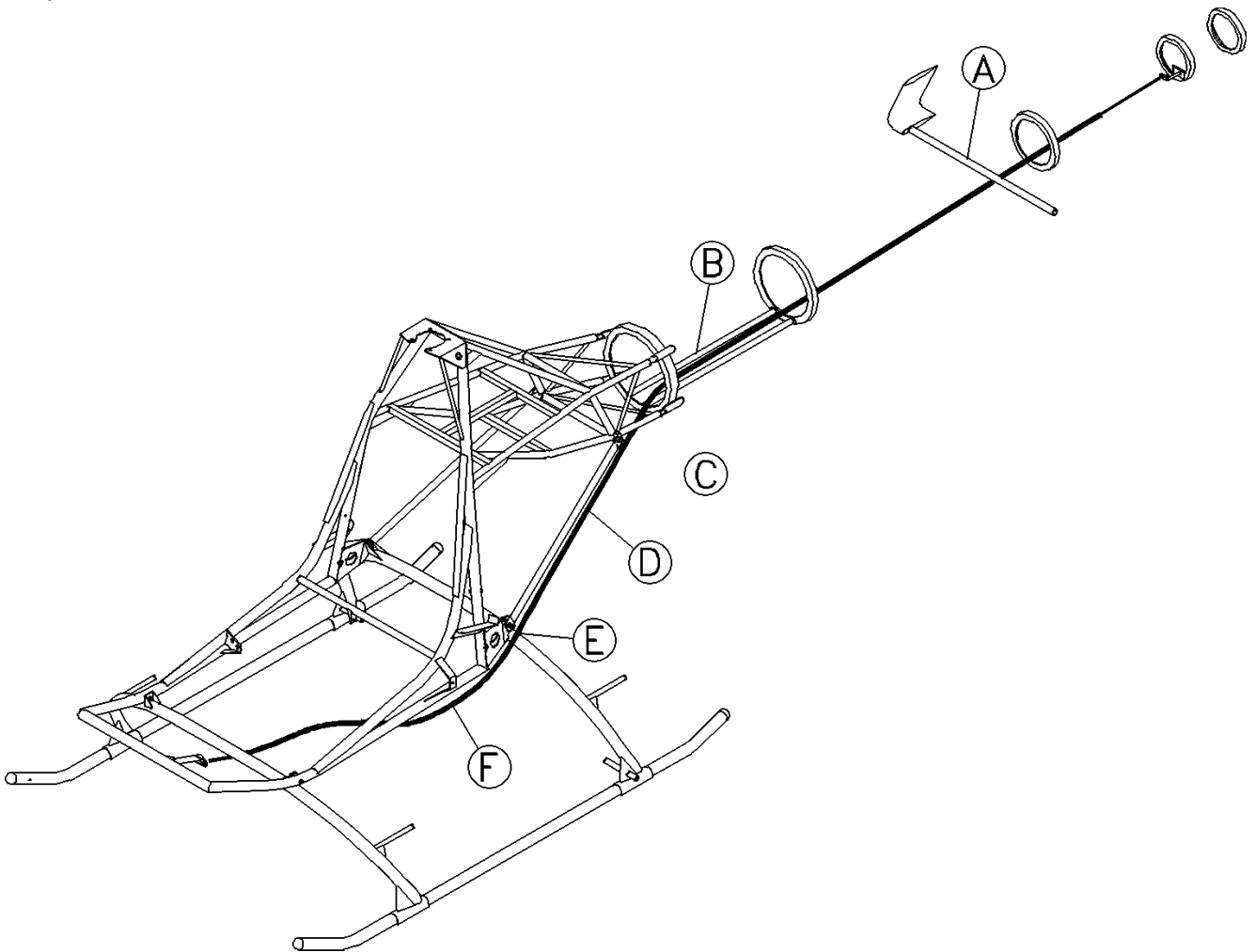
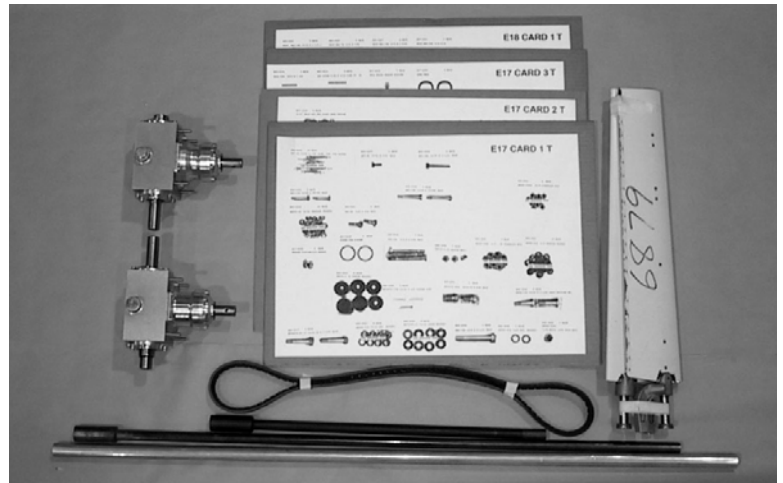

Photo #1

Use prints E17-2000 and E17-2001 and templates E17-1, E17-2 and E17-3 when constructing the tail rotor assembly.
Parts as received from RotorWay International.



DRIVE SHAFTS AND GEARBOXES

Photo #2

Install the spline shafts into the ends of the aluminum middle shaft. The spline shafts should extend equal distances on both ends, and the overall length with spline shafts should be 56-5/8 inches.

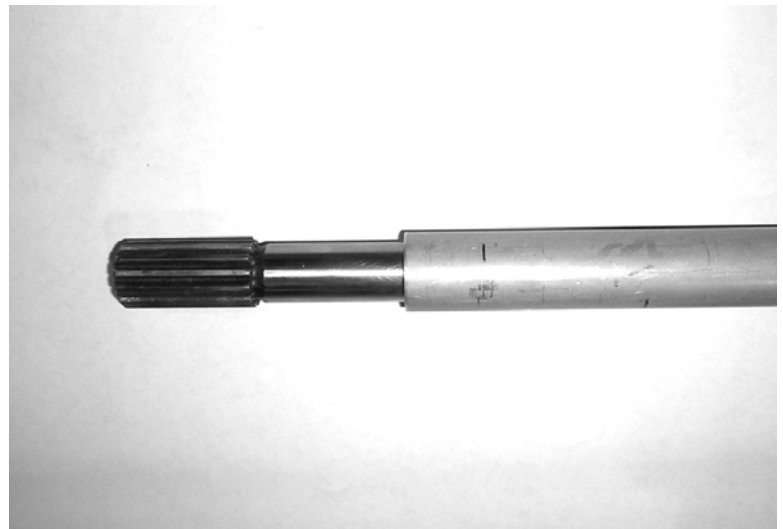

Photo #3

Drill the bolt holes, maintaining the 56-5/8" distance from end to end. Each end should have two 1/4" holes, 1" and 3" from the end, 90 degrees apart. Note: Throughout this installation, use a drill press and V-blocks to ensure accurately drilled holes. After drilling, mark the position and placement of each spline shaft and remove them from the aluminum middle shaft. Deburr all drilled holes.

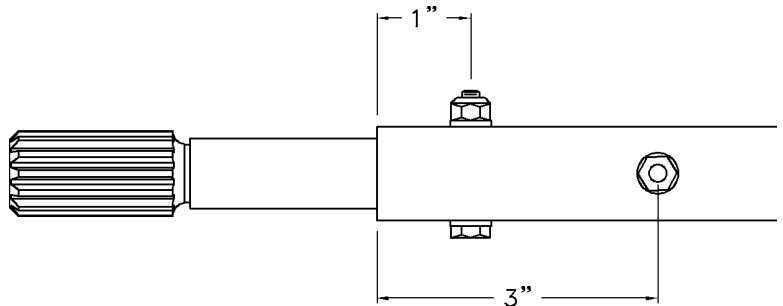



Photo #4

Install the bearing and bearing flanges on one spline shaft, then re-install it on the matching end of the aluminum middle shaft. Do not install bolts or set the bearing lock ring yet.

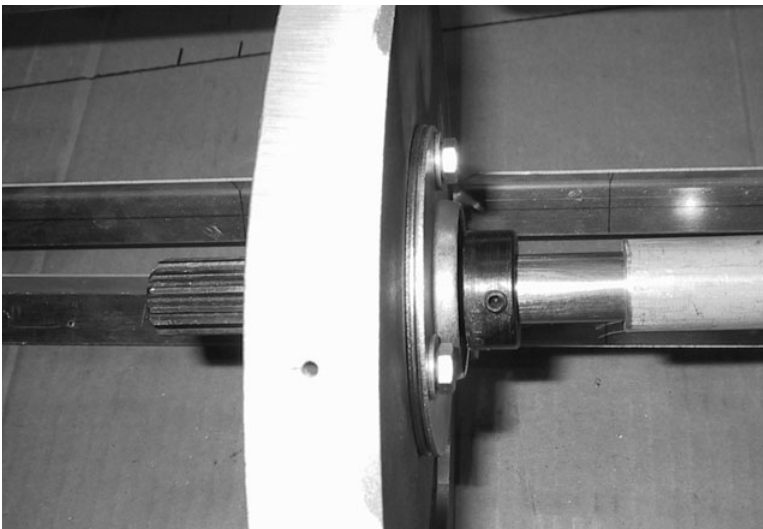

Photo #5

Install the middle shaft into the tail boom by feeding the end with the bearing through the inspection hole at the number two bulkhead, guiding the shaft towards the rear of the tail boom. Then guide the opposite end through the bearing hole in the number two bulkhead, towards the front. Allow the shaft to extend to the front of the tail boom, then install the other spline shaft, bearing and flanges. Position the shaft between the 2nd and 3rd bulkheads, with bearing flanges on the front of the bulkheads, and install the hardware.

This photo shows the shaft at the third bulkhead after installation. For clarity, the tail boom skin is not shown in these photos.

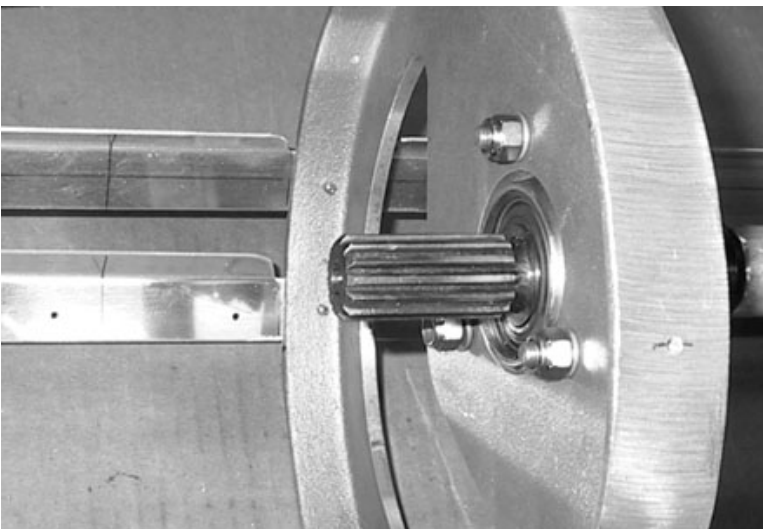

Photo #6

The splined portion of the shaft should extend equally from the bearings on each end. The shaft can be moved forward or aft in the bearings to achieve equal distances before the lock rings are set.

Photo #7

On each gearbox, the bolt hole for the universal joint is pre-drilled in the shaft. The universal joint is also pre-drilled. Install the joint on the gearbox shaft and align the holes. Drill through with a 1/4" drill, then install the hardware.

Slide each steel drive shaft into the appropriate universal joint. (The shorter shaft is used in front, between bulkheads 1 and 2.) This should be a snug fit. Some polishing of the shaft may be required to allow for ease of assembly.

Note: The rear gearbox is supplied with an alignment shaft to keep internal parts aligned during shipping. **DO NOT REMOVE THIS SHAFT** until the tail rotor shaft is installed (see photo 33).

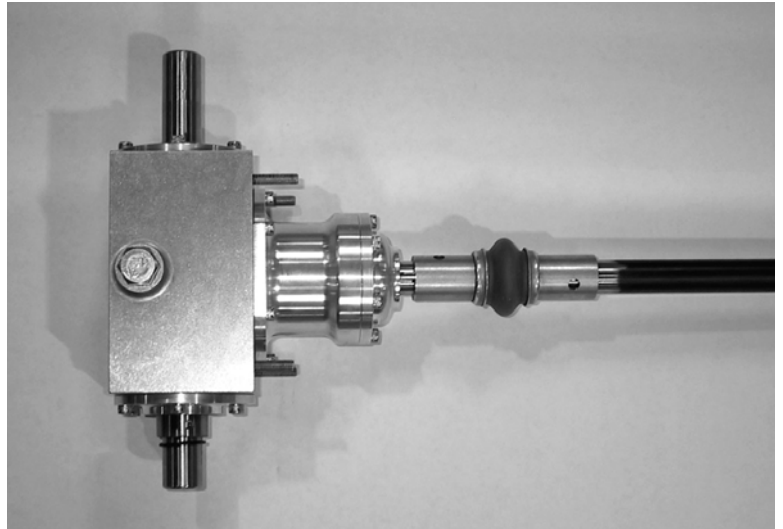

Photo #8

Install both gearboxes on bulkheads while engaging the spline couplings. When installed, the front and rear shafts must not be bottomed in the spline couplings. Both spline couplings should engage the splines an equal amount, with approximately 1/8" fore/aft play. Trimming of either the front or rear shaft (the end opposite of the splines) is acceptable if necessary. The center shaft can be repositioned if needed by sliding it fore/aft in the bearings. When the correct position is found, set the bearing lock rings in the direction of rotation of the shaft (clockwise looking aft) and tighten the set screws. Remove gearboxes, drill the holes in the shaft at the universal joints, and install the hardware.

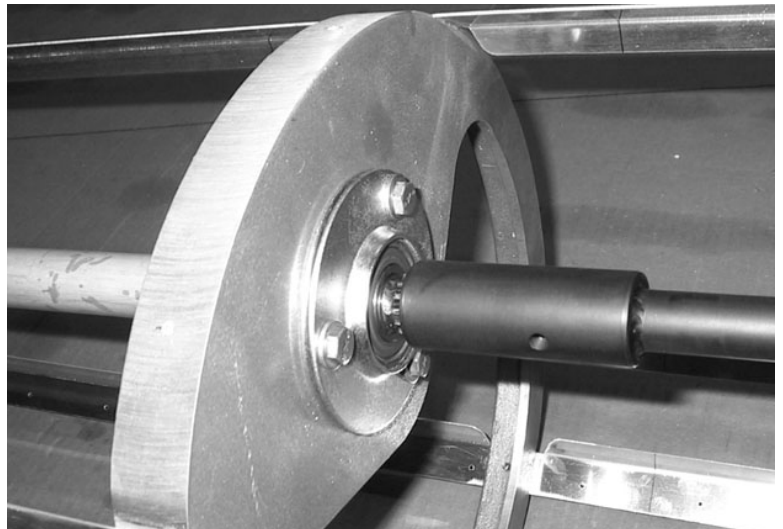
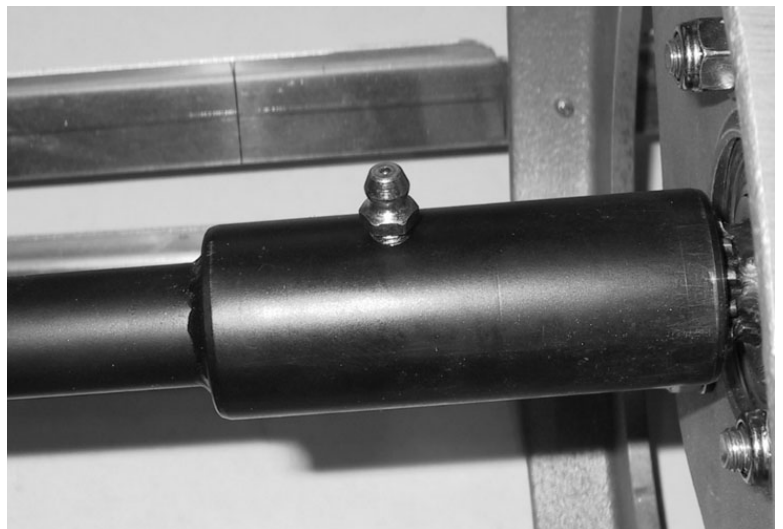

Photo #9

Install the grease fittings on the spline couplings.



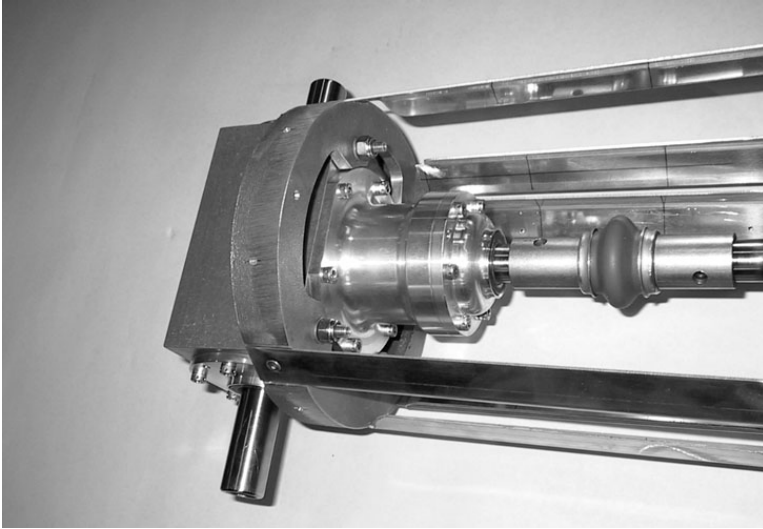

Photo #10

Reinstall the rear gearbox. Install the nuts and washers.

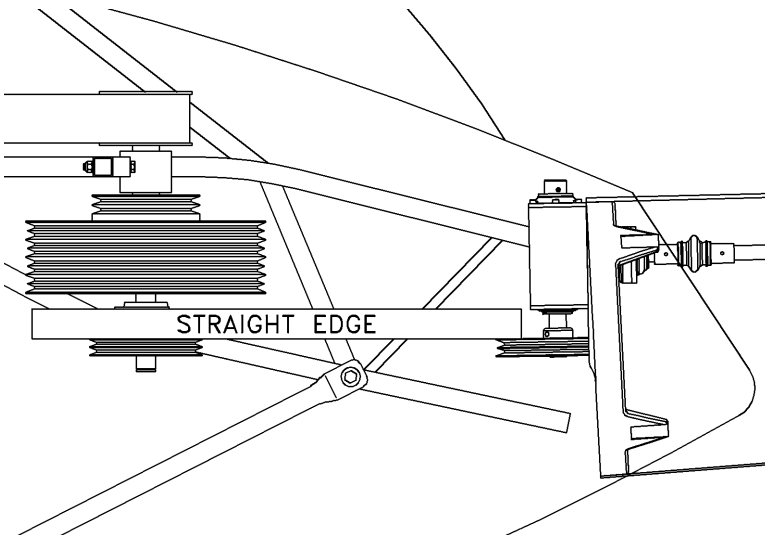

Photo #11

Reinstall the front gearbox on the first bulkhead. Place the pulley on the input shaft of the gearbox. Using a straight edge, align the pulley vertically with the tail rotor drive pulley on the secondary assembly. The pulleys should also be parallel. If not, add a shim between the front gearbox and the bulkhead. The shim should cover the entire width of the gearbox. When the pulley is at the right height and parallel with the secondary pulley, drill the shaft and install the hardware. (To ensure accuracy, remove the gearbox and use a drill press to drill the bolt hole.)

Note: Final installation of the pulley on the secondary shaft should not be done until after the cooling system is installed. See Section 18.

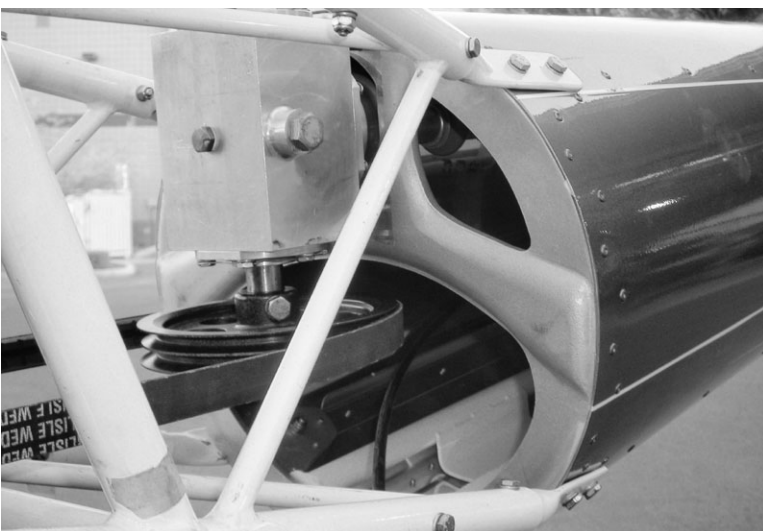

Photo #12

Install the drive belt between the secondary assembly and the front gearbox. The belt should not be forced over the pulleys. If necessary, loosen the front gearbox from the bulkhead to install the belt.

Photo #13

Assemble the tensioner pulley to the arm and install it on the airframe. Vertical adjustment can be made by shimming the upper pulley spacer.

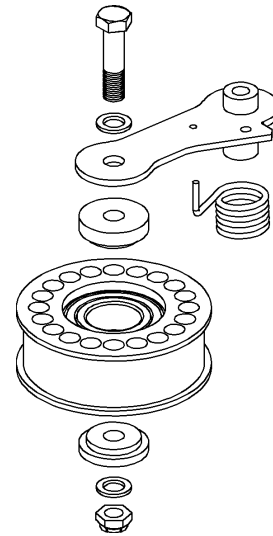

Photo #14

The tensioner pulley applies pressure against the back of the belt. To set static tension and to limit travel in the opposite direction, install the tensioner arm stop (arrow). This will prevent the pulley from contacting the airframe. Find best position of the stop, then drill and install the bolt, nut and washers.

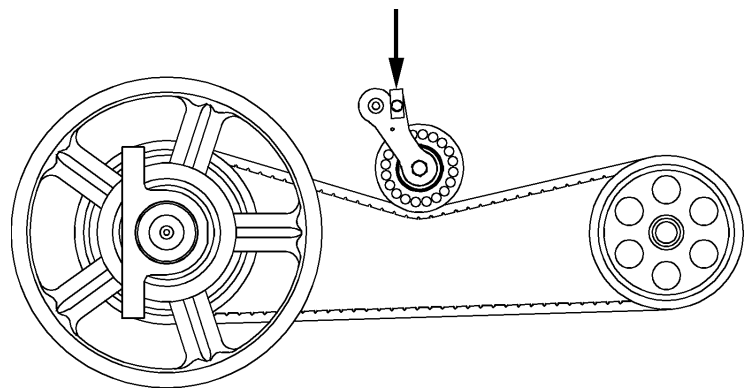
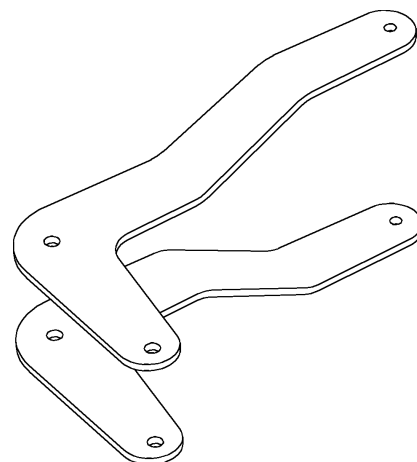

Photo #15

Use template E17-3 to make the tail rotor pitch actuator arms. After cutting and drilling, bend the arms at the bend lines as shown. Each arm should bend outward about 3/4 inch.



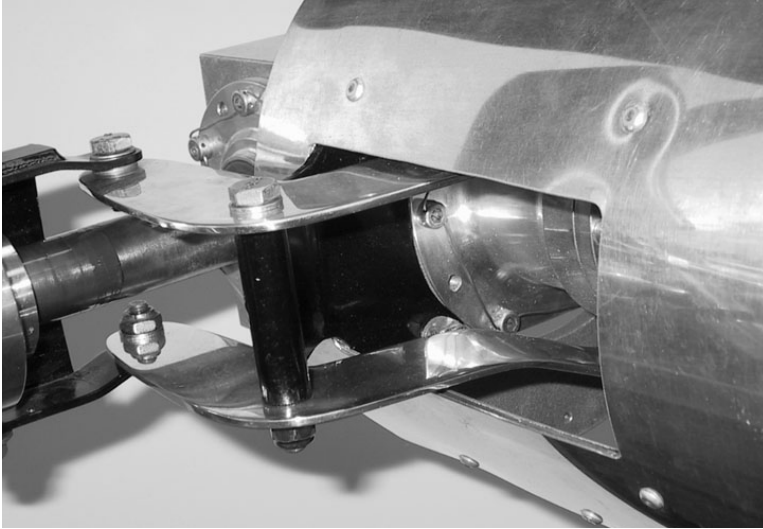

Photo #16

Cut the tail boom skin to clear the pitch actuator arms as shown, removing no more than necessary. Install the actuator arm bracket on the 5th bulkhead and install the actuator arms, spacers and hardware. Apply grease to the pivot bolt on assembly.

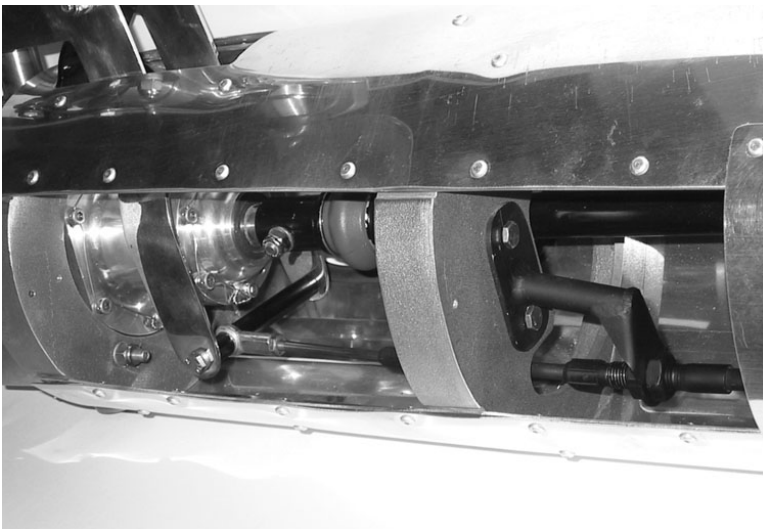
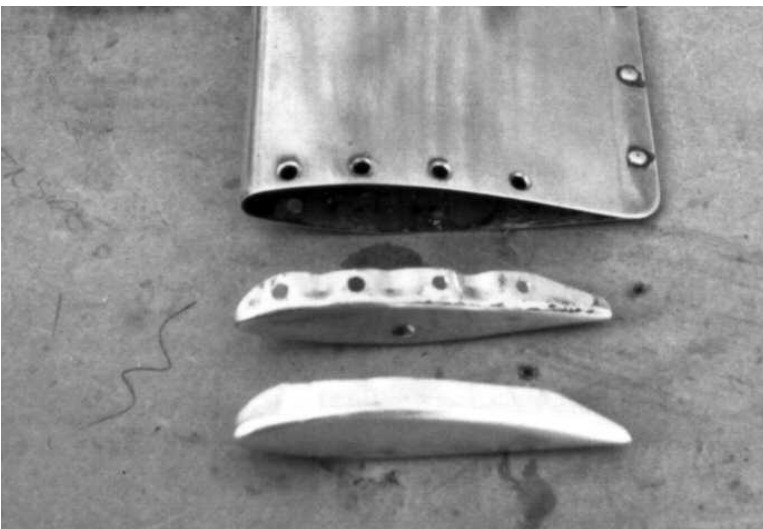

Photo #17

Install the cable stop bracket on the 4th bulkhead (shown here from below). Route the tail rotor cable through the tail boom according to the diagram at the beginning of this chapter, Section 13 Page B. Connect the cable to the actuator arms using the female rod end and actuator arm spacers as shown.



TAIL ROTOR BLADES

Photo #18

Remove the plastic from the blades and fit the end caps. It may be necessary to bend the cap slightly to achieve a good fit.

Note: Do not install the pop rivets until after balancing the blades.

Photo #19

The cap does not need to fit perfectly to the airfoil of the blades. Countersink just enough to make the head of the pop rivet flush with the airfoil. Do not countersink too far or the pop rivet will not hold the end caps.

Note: Drill a 3/16 inch hole in the middle of each end cap as shown, so that grease thrown out by centrifugal force during operation will not build up inside the blade.

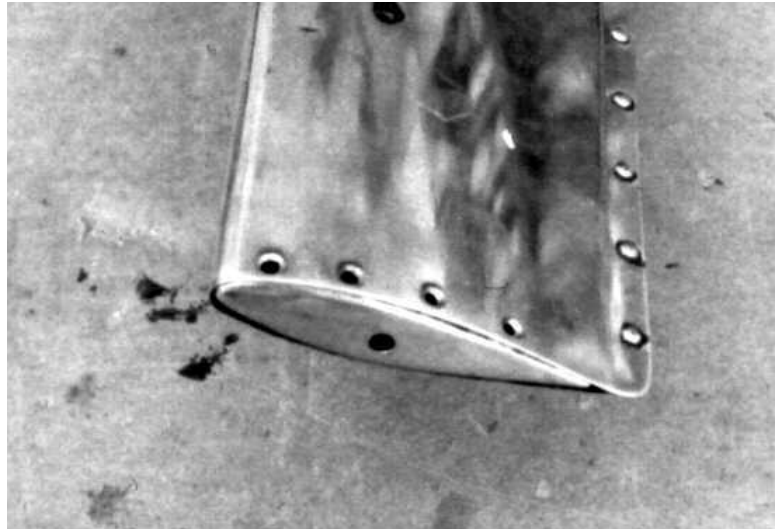

Photo #20

This shows how the end cap will look when final installed. Do not install pop rivets until blades have been balanced.

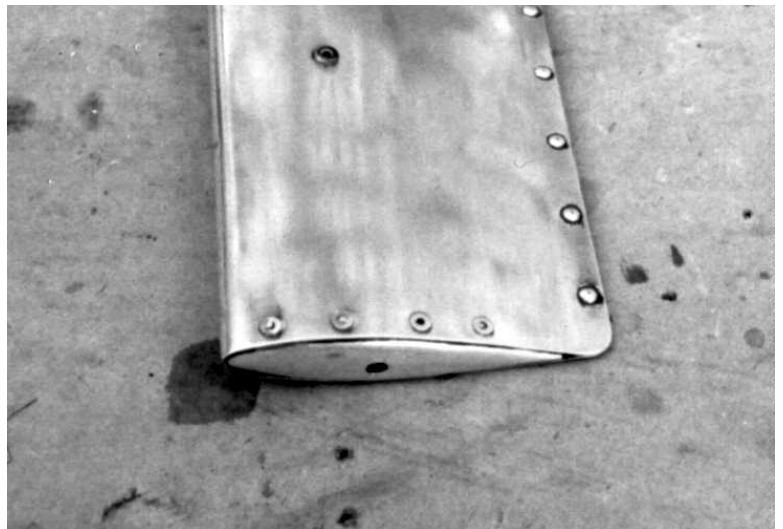
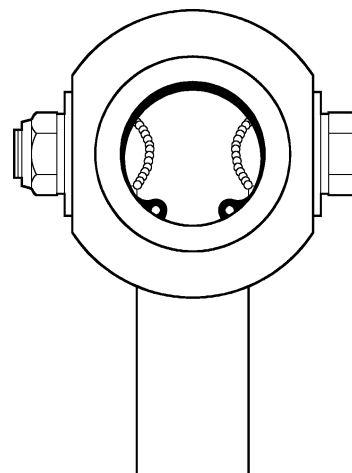

Photo #21

Install the tail rotor barrel on the shaft. Then install the inner snap rings with the numbers (flat side) facing the shaft. The opening in the snap rings should be in line with the shaft.



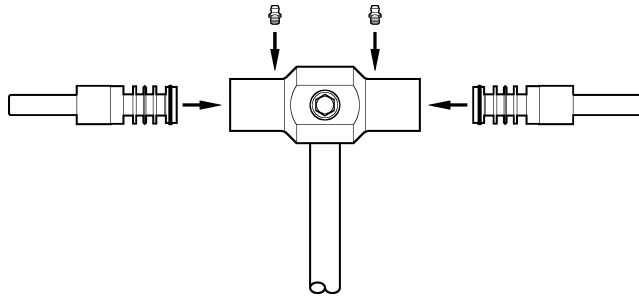

Photo #22

Mount the O-rings on the pitch pins. Grease the pitch pins, thrust bearings and alignment bearings, and assemble as shown on print E17-2000. Install the pitch pin assembly in the tail rotor barrel. Then install the outer snap rings with the flat side out, and with the openings parallel to the tail rotor shaft. Also, install the grease fittings in the tail rotor barrel.

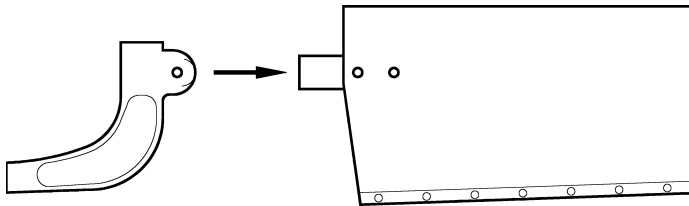

Photo #23

Position the pitch horns on the blade spars.

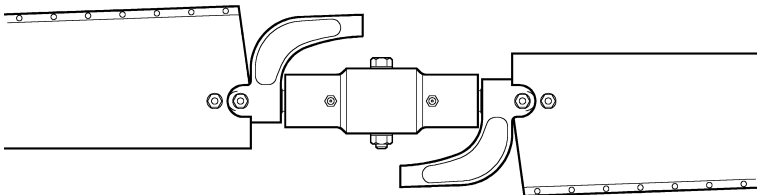

Photo #24

Install the blades and pitch horns on the pitch pins.

Photo #25

Build a balancing fixture like the one shown using a vise, a 2x4 board, and two pieces of .050" aluminum. The top edges must be level in all directions.



Photo #26

Use small pieces of foam to wedge the tail rotor blades as shown and to keep the tail rotor barrel 90 degrees to the shaft while balancing. Use the bearings and pulleys from the fan drive countershaft as a counter balance. Extend the blades as far away from the edge of the aluminum fixture as the counter balance will allow.

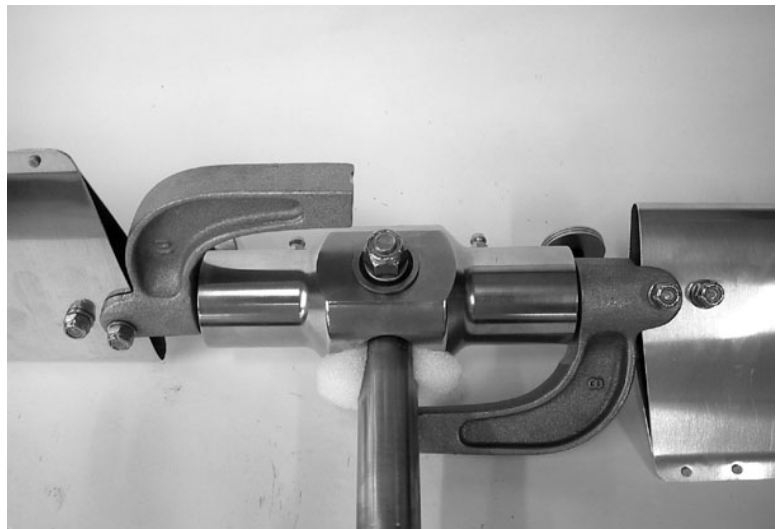
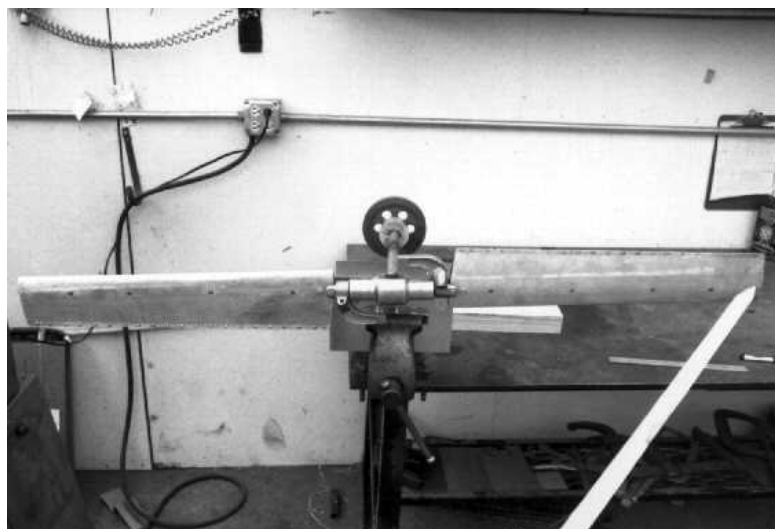

Photo #27

If weight is needed for horizontal balance, add it to the inside of the airfoil at the tip.
Note: Blades must be forced out against the thrust bearings so that they will be in the same position as if forced out by centrifugal force when in flight.



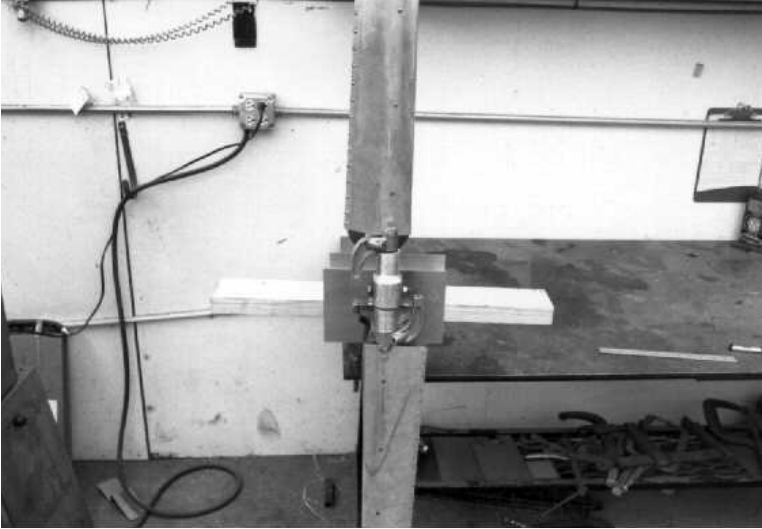

Photo #28

Balance the tail rotor vertically. The blades must be held outward the same as when in flight.

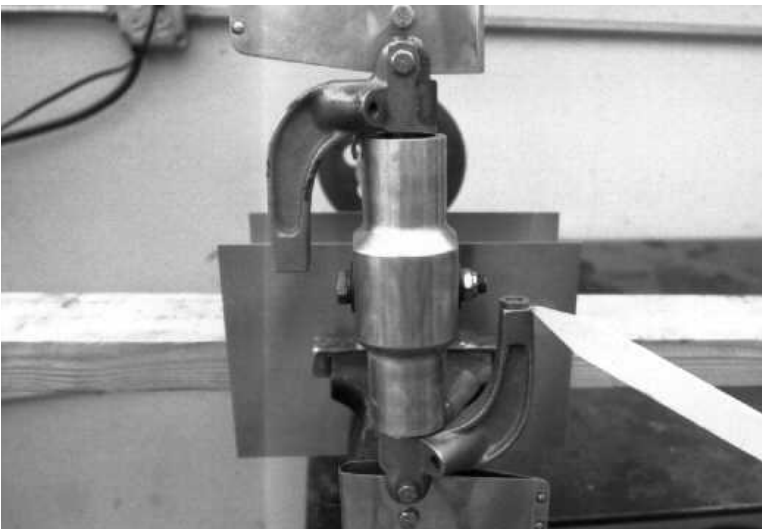

Photo #29

If weight is needed to achieve balance, add washers to the pitch horn bolt (between the rod end and the head of the bolt). If more than 4 regular 5/16" washers are required, contact RotorWay Customer Service.



CARRIAGE SLIDER

Photo #30

Make a reference mark on the tail rotor shaft. Measure 1-5/16 inch (1.312) from the key towards the tail rotor barrel, then mark the shaft using a felt tip marker or pencil.

Note: The mark does not have to be permanent. Do not use a scribe or other sharp object to mark the shaft.

Photo #31

Grease the tail rotor shaft, the bore of the carriage slider, and the quad seals. Install the notched end cap (E17-6271) on the tail rotor shaft. Install a quad seal, lifting to prevent damage when sliding over the key on the shaft. Install the carriage slider assembly on the shaft in the direction shown, engaging the key in the keyway.



Photo #32

Seat the quad seal inside the end cap, then place the cap on the carriage slider assembly. Install the cone point set screws so that the tip of the screw engages in the groove in the slider. Install the other end cap in the same manner.

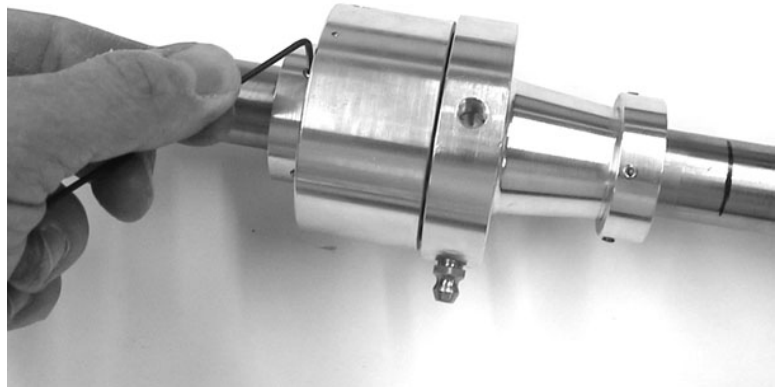

TAIL ROTOR SHAFT

Photo #33

The rear gearbox is shipped with a shaft which keeps the internal parts aligned during shipping. This alignment shaft should not be removed until immediately before installing the tail rotor shaft.

Also before inserting the tail rotor shaft assembly into the gearbox, the O-ring (part number E18-3550) must be installed inside the gearbox. The O-ring groove is deep within the bore (about 2 inches). Slide the alignment shaft out towards the passenger side. Lubricate the bore and O-ring with oil, and insert the O-ring in the groove.

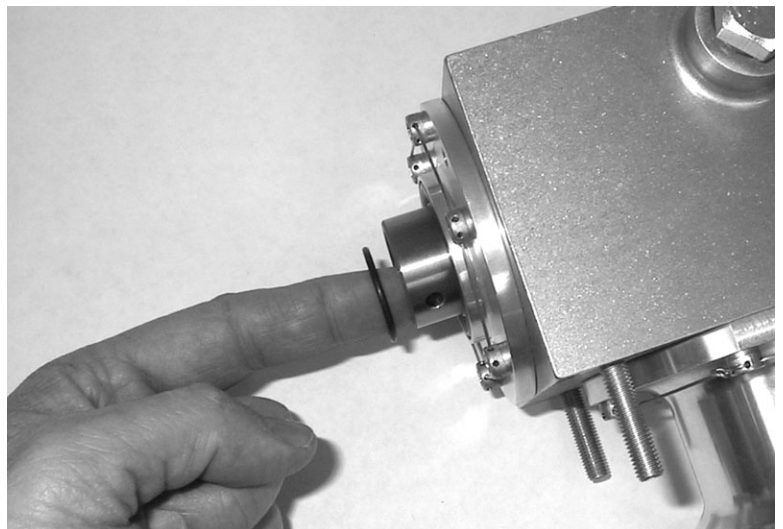



Photo #34

Before installing, inspect the end of the tail rotor shaft. Polish if necessary to remove any sharp edges or burrs that may damage the O-ring on installation. Then remove the alignment shaft completely, oil the shaft and install the shaft assembly in the gearbox.

The end of the tail rotor shaft should align with the end of the bore in the gearbox. Using a smaller drill bit, drill the shaft through the existing holes, one side at a time. Then, using a 3/16" bit, drill all the way through both sides.

Install the roll pin and add safety wire.

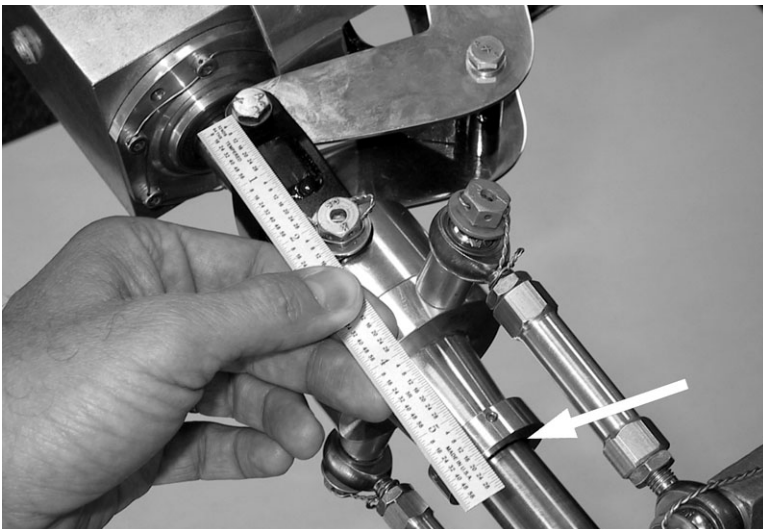

Photo #35

Place the carriage slider on the reference mark made previously (arrow). Pivot the actuator arms so that they are as close to the gearbox as possible. Measure the distance between the hole in the actuator arm and the hole in the carriage slider, and use this measurement to drill the holes in the slider to actuator arm clevis (E17-9010). The distance should be 2-1/4" to 2-3/8" as shown on print E17-2001. The clevis should not contact the inner end cap throughout the full range of travel (see next photo).

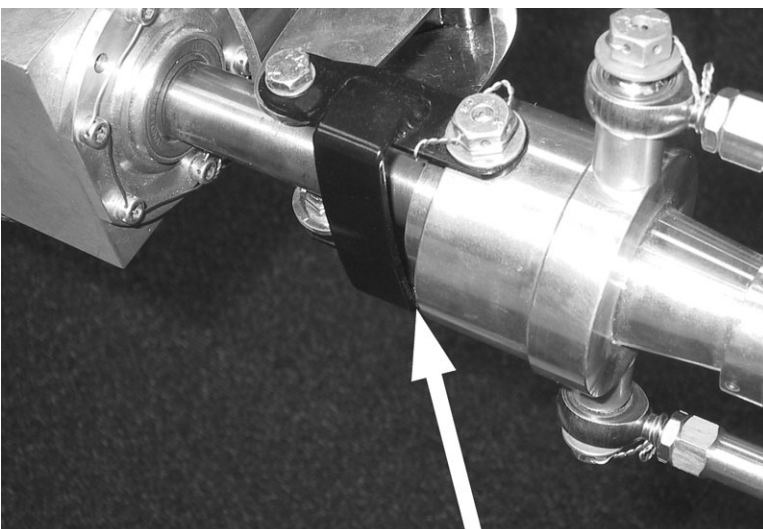

Photo #36

Make sure that the clevis does not contact the inner end cap throughout the full range of travel.

Photo #37

Install the grease fitting (E17-6250). Use a grease gun to slowly inject one "shot" of grease, while moving the slider back and forth to spread the grease evenly. Add grease again every 25 hours of operation or as needed.



Photo #38

If necessary, use a washer as a spacer between the rod end and the pitch horn to get the rod end centered on the pivot bolt. Whatever weight is added to one pitch horn must be added to the other. If a washer is added to get vertical balance, it must be installed between the rod end and the head of the bolt.

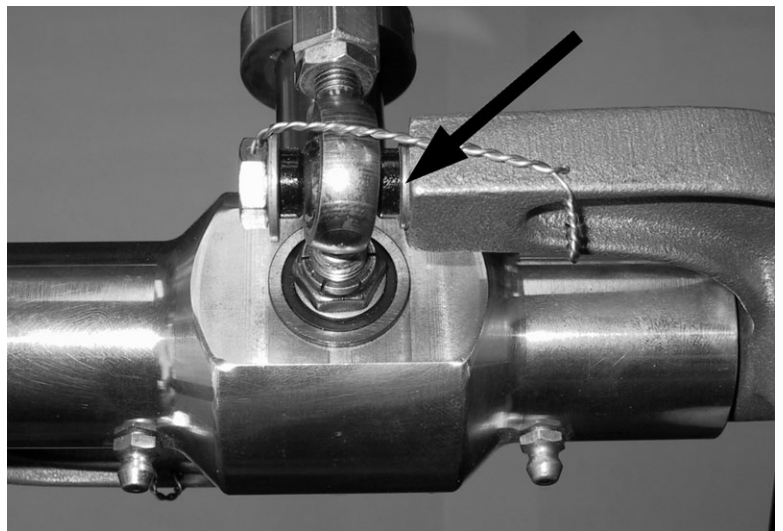
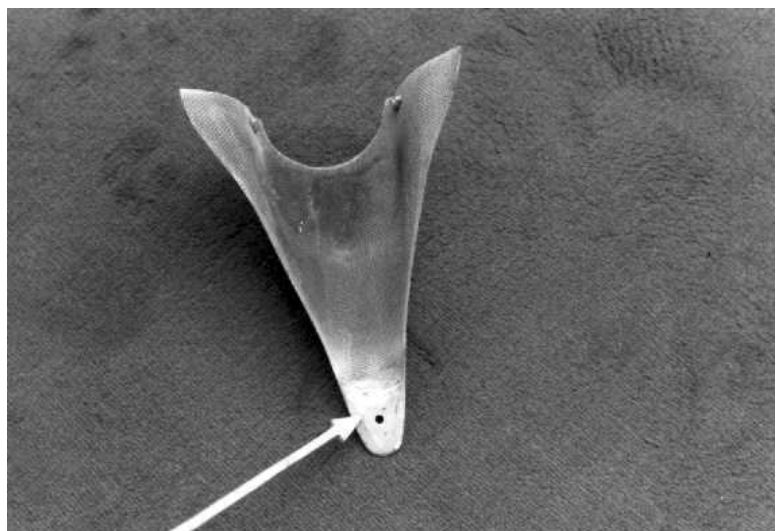

Photo #39

Fill the small end of the slider cover using fiberglass mat and resin and allow it to dry. This will provide enough material to countersink for the screw (see next photo). Fit the slider cover to the tail boom and tail cone cover, moving it fore/aft to determine best fit.



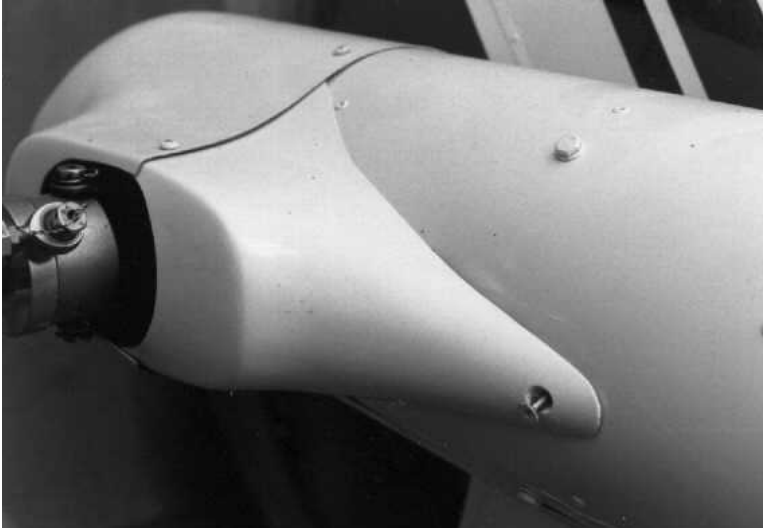

Photo #40

Slide the fiberglass tail cone cover over the end of the tail boom. Overlap the 5th bulkhead. Attach the cover to the bulkhead with two 8-32 screws on top and two on bottom. Drill and tap the bulkhead for the screws.

Fasten the covers together with a screw and nut plate on top and on bottom, near the opening for the shaft. Attach the front of the slider cover with the 3/16 countersunk screw and a nut plate.

Note: Avoid existing rivets and other obstacles when locating the fasteners.



Photo #41

Close up of the tail rotor hub area. Make sure the fiberglass parts do not interfere with any tail rotor operations.